

BLACKMER NG COMPRESSORS

Installation, Operation, and Maintenance Instructions

MODEL: NG942B, NGS942B

960487

INSTRUCTIONS CB6A-050

Section	601
Effective	Oct 2019
Replaces	Feb 2019

TABLE OF CONTENTS

SAFETY DATA	1	OPERATION	
GENERAL INFORMATION		Pre-Startup Check List.....	9
Compressor Data	2	Start Up Procedure	9
Nameplate Data.....	3	MAINTENANCE	
Maximizing Compressor Life.....	4	Service Schedule	10
INSTALLATION		Tool List	11
Location and Piping	5	Bolt Torque Table.....	11
Mounting the Compressor Unit	5	Crankcase Lubrication	12
Compressor Flywheel.....	6	Setting the Oil Pressure	12
V-Belt Drive.....	6	COMPRESSOR DISASSEMBLY	13
Seal Arrangements.....	6	COMPRESSOR ASSEMBLY	15
Typical Compressor, Drawing	7	VALVE REPLACEMENT	17
Relief Valves	8	SEAL (PACKING) REPLACEMENT	18
Liquid Traps	8	BEARING REPLACEMENT	20
Temperature and Pressure Switches	8	OIL PUMP REPLACEMENT	21
Pressure Gauges.....	8	EXTENDED STORAGE	21
		TROUBLESHOOTING	22

SAFETY DATA



This is a SAFETY ALERT SYMBOL.

When you see this symbol on the product, or in the manual, look for one of the following signal words and be alert to the potential for personal injury or property damage.



Warns of hazards that WILL cause serious personal injury, death or major property damage.



Warns of hazards that CAN cause serious personal injury, death or major property damage.



Warns of hazards that CAN cause personal injury, or property damage.

NOTICE

Indicates special instructions which are very important and must be followed.

NOTICE

Blackmer compressors **MUST** only be installed in systems which have been designed by qualified engineering personnel. The system **MUST** conform to all applicable local and national regulations and safety standards.

These instructions are intended to assist in the installation and operation of Blackmer compressors and **MUST** be kept with the compressor.

Blackmer compressor service and maintenance shall be performed by qualified technicians **ONLY**. Service and maintenance shall conform to all applicable local and national regulations and safety standards.

Thoroughly review this manual, all instructions and hazard warnings, **BEFORE** performing any work on the compressor.

Maintain **ALL** system and compressor operation and hazard warning decals.

For handling liquefied gas, NFPA Pamphlet 58 should be consulted.

NOTICE

The NGS942 is designed for use in Sour Gas Applications. Persons maintaining, repairing, or working near the compressor or surrounding area must have adequate safety training and protection.



H₂S atmospheres can cause serious personal injury or death.

H₂S atmospheres can cause serious personal injury or death.

SAFETY DATA

⚠ DANGER



Flammable gas can cause death, serious personal injury or property damage

Flammable gas and/or liquid can form explosive mixtures with air causing property damage, serious personal injury or death

⚠ WARNING



Hazardous pressure can cause serious personal injury or property damage

Failure to relieve system pressure prior to performing compressor service or maintenance can cause serious personal injury or property damage.

⚠ WARNING



Hazardous machinery can cause serious personal injury.

Failure to disconnect and lockout electrical power or engine drive before attempting maintenance can cause severe personal injury or death

⚠ WARNING



Hazardous voltage. Can shock, burn or cause death.

Failure to disconnect and lockout electrical power before attempting maintenance can cause shock, burns or death

⚠ WARNING



Hazardous or toxic fluids can cause serious injury.

If handling hazardous or toxic fluids, system must be flushed and decontaminated, inside and out, prior to performing service or maintenance

⚠ WARNING



Hazardous pressure can cause serious personal injury or property damage

Disconnecting fluid or pressure containment components during compressor operation can cause serious personal injury, death or major property damage

⚠ WARNING



Hazardous gases can cause property damage, personal injury or death

Explosive gas can cause property damage, personal injury, or death.

⚠ CAUTION



Extreme Heat can cause personal injury or property damage

Extreme heat can cause personal injury or property damage

COMPRESSOR DATA

COMPRESSOR DATA	NG942B, NGS942B
MAWP - psia (Bar)	350 (24.1)
Displacement CFM (m ³ /hr) @ 350 rpm (Minimum Speed) @ 835 rpm (Maximum Speed) *	52.5 (89.1) 125.1 (213)
Max. BHP (kw)	50 (37)
Maximum Discharge Temperature	350°F (176°C)
Rotation Direction	Either Direction
Bore x Stroke, Two Double-Acting Cylinders	in. (mm) 4.625 x 4 (117 x 102)
Type: Single-stage, vertical, air-cooled, non-lubricated, reciprocating compressor.	
Critical Dimensions: See Document CB242.	

* NOTE: Reduce maximum speeds by 9% for continuous duty operation.

Table 1 - Compressor Data

GENERAL INFORMATION

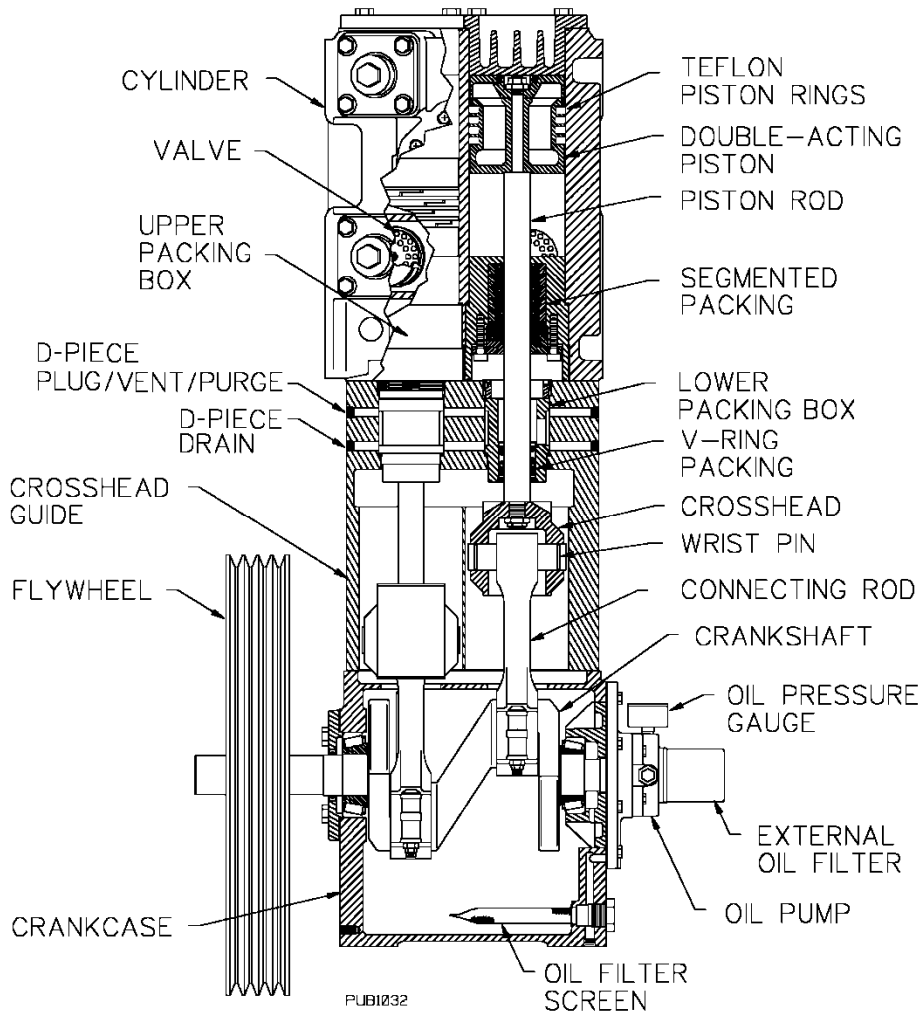

Figure 1 – NG942B Compressor

MODEL: NG ID#: _____ SERIAL NO: _____

Before proceeding:

1. Note the nameplate data in the space provided above.
2. Obtain the appropriate parts lists for the model in question.

Manuals and Parts Lists for Blackmer products may be obtained from Blackmer's website (www.blackmer.com) or by contacting Blackmer's Customer Service.

NAMEPLATE DATA

A nameplate is attached to the side of all Blackmer compressors showing the Model No., I.D. No., and Serial No. These numbers should be available when information or parts are needed for a particular unit.

The basic size and type of the compressor is indicated by "Model No." A suffix letter is used on most models to indicate the version.

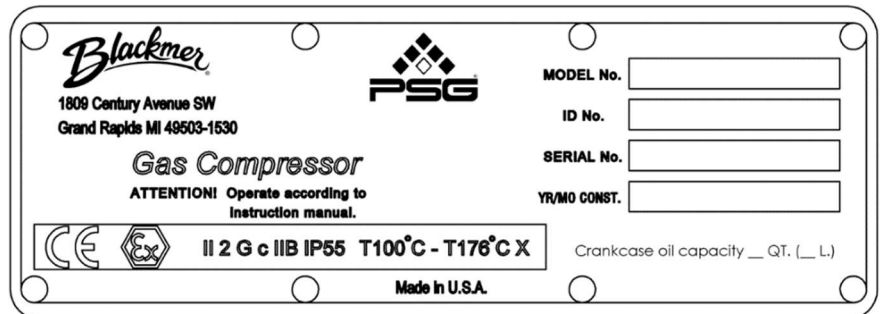

Figure 2 - Compressor Nameplate

For detailed ATEX Declaration information, refer to FORM 576 found in the Certification section of Blackmer's website.

GENERAL INFORMATION

An 11 character "I.D. No." identifies the construction of the compressor.

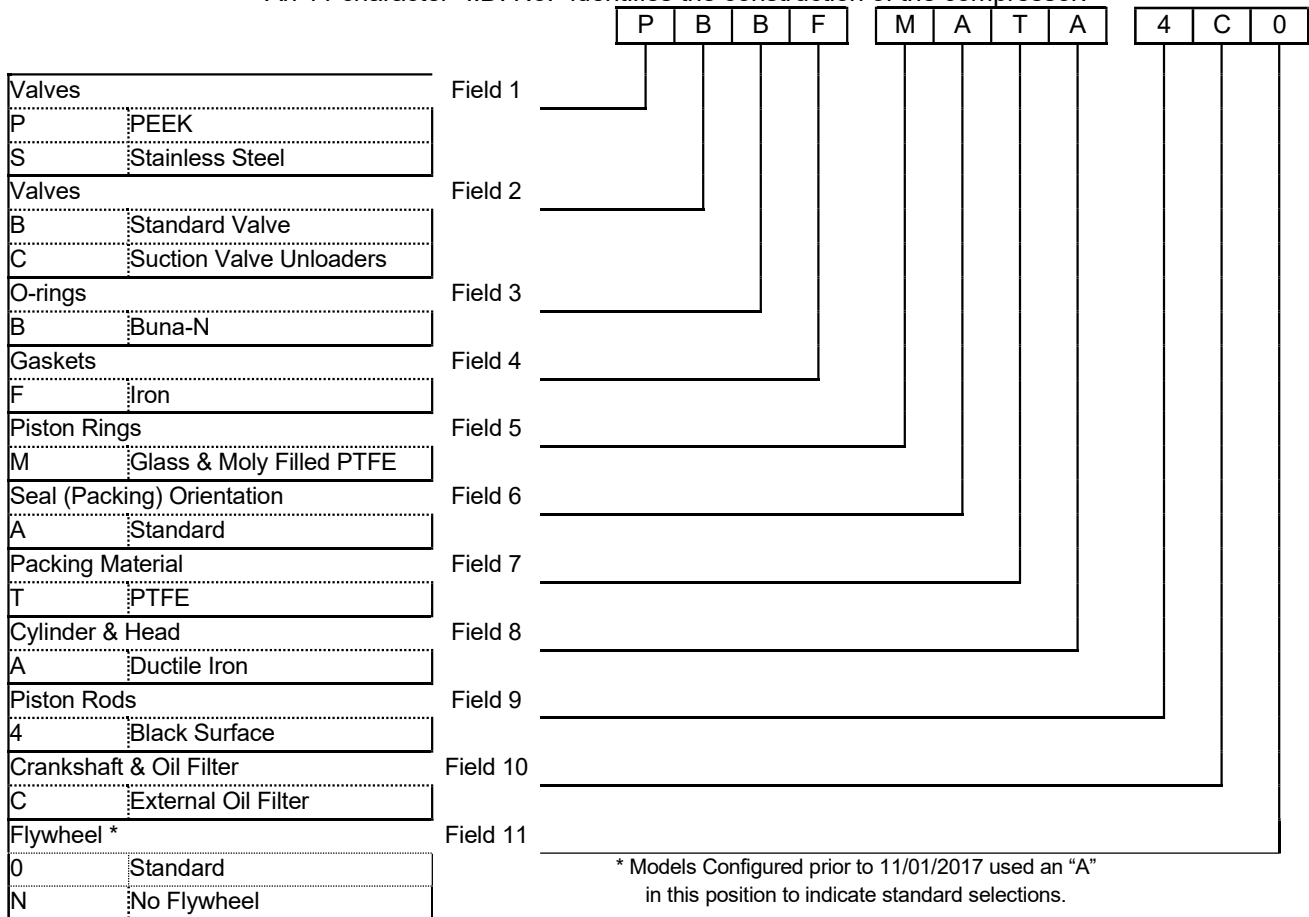

Table 2 - ID Number Key

MAXIMIZING COMPRESSOR LIFE

Life of critical compressor components such as piston rings, valves and packing will vary considerably with each application, installation, and operating procedures. Premature failure of wear parts can often be attributed to one of the following causes:

1. Excessive Temperatures

Primary causes are:

- Operating at pressures other than those originally specified.
- Handling a different gas than originally specified.
- Clogged strainer or filter elements.
- Line sizes too small, or other flow restrictions.
- Excessive ambient temperature or suction gas temperature.
- Valve problems. (See Foreign Material.)
- Badly worn piston rings. (See Foreign Material.)

Lower operating temperatures will increase valve and piston ring life significantly.

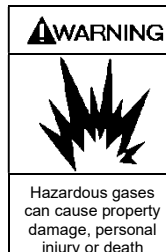

Extreme temperatures caused by abnormally high discharge pressure or valve problems can be a source of ignition in explosive atmospheres causing severe personal injury or death.

2. Foreign Material

Solid particles in the gas stream will:

- Rapidly wear the piston rings and score the cylinder wall.
- Destroy the rod packing causing excessive leakage and score the piston rods.
- Lodge in the valves causing loss of capacity and broken valve plates and springs.

Liquid in the gas stream may:

- Cause broken valve plates and springs.
- Destroy the compressor.

On new installations, it is suggested that the valves and piston rings be inspected after the first few hundred hours of operation. This will give an early indication of any abnormal problems and allow for corrective action to be taken before a costly failure results. Although piston ring life will vary from application to application, wear will be fairly consistent on subsequent sets of rings.

INSTALLATION

NOTICE:

Blackmer compressors must only be installed in systems designed by qualified engineering personnel. System design must conform with all applicable regulations and codes and provide warning of all system hazards.

NOTICE:

This compressor shall be installed in accordance with the requirements of NFPA 58 and all applicable local, state and national regulations.



- ▲ Install, ground and wire to local and National Electrical Code requirements.
- ▲ Install an all-leg disconnect switch near the unit motor.
- ▲ Disconnect and lockout electrical power before installation or service

- ▲ Electrical supply **MUST** match motor nameplate specifications.
- ▲ Motors equipped with thermal protection automatically disconnect motor electrical circuit when overload exists. Motor can start unexpectedly and without warning.

LOCATION AND PIPING

Compressor life and performance can be significantly reduced when installed in an improperly designed system. Before starting layout and installation of the piping system, consider the following:

1. All piping must be leak free to a pressure of 1.5 times the maximum system pressure.
NOTICE: If the system is to be hydro-statically tested, the compressor MUST be isolated. Liquid entering the compressor will cause damage and void the warranty.
2. A strainer should be installed in the inlet line to protect the compressor from foreign matter. A #30 mesh screen or finer is recommended. Strainers **must** be cleaned every 180 days, or more frequently if the system requires.
3. Expansion joints, placed within 36" (0.9 m) of the compressor, will compensate for expansion and contraction of the pipes. Contact the flexible connector/hose manufacturer for required maintenance/care and design assistance in their use.
4. Piping **must** be adequately supported to ensure that no piping loads are placed upon the compressor.
5. Both suction and discharge piping should slope down from the compressor. The compressor should not be placed at a low point in the piping system.



Discharge piping surface temperatures may be hot during operation (over 158°F, 70°C). Temperatures should be monitored and adequate warnings posted.

MOUNTING THE COMPRESSOR UNIT

A solid foundation reduces noise and vibration, and will improve compressor performance. On permanent installations, it is recommended the compressor be secured by anchor bolts as shown. This arrangement allows for slight shifting of position to accommodate alignment with the mounting holes in the base plate.

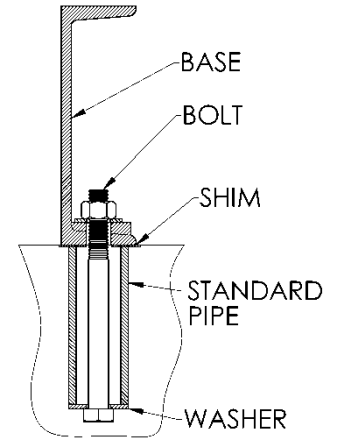

Figure 3 - Anchor Bolt

Set the anchor bolts in concrete for new foundations. When compressors are to be located on existing concrete floors, holes should be drilled into the concrete to hold the anchor bolts.

To keep vibration at a minimum, in addition to a solid concrete foundation, it is important that the concrete be located on a stable soil foundation. The base must have complete contact along its entire length with the foundation. Visible separations will result in vibrations which are magnified in the upper part of the unit.

Check compressor mounting bolts and baseplate anchor bolts regularly.

See CB220 "Compressor Bases, Skids and Foundations" for additional information.

INSTALLATION

COMPRESSOR DRIVE SYSTEMS

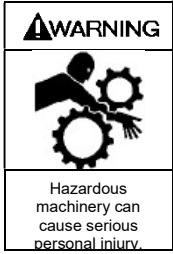

Failure to disconnect and lockout electrical power or engine drive before attempting maintenance can cause severe personal injury or death

Hazardous machinery can cause serious personal injury.

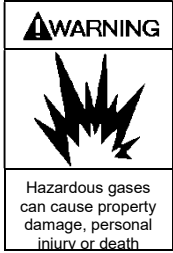

Flywheel guard contact with moving parts may be a source of ignition in explosive atmospheres causing severe personal injury or death

Hazardous gases can cause property damage, personal injury or death

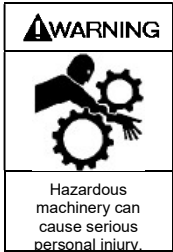

Operation without guards in place can cause serious personal injury, major property damage or death.

Hazardous machinery can cause serious personal injury.

FLYWHEEL

Blackmer compressors are fitted with flywheels which **MUST** be used regardless of the type of drive system employed.

Flywheels must be properly installed and aligned:

1. Ensure that the mating surface between the hub and flywheel are clean and dry – do not use a lubricant.
2. Install the hub and key on clean compressor shaft, flange end first.
3. Tighten the hub setscrew just enough to prevent it from sliding on the shaft – do not overtighten.
4. Place the flywheel on the hub and loosely thread the capscrews with lockwashers into the assembly. Do not use lubricant on the capscrews.
5. Tighten all capscrews evenly and progressively in rotation to the torque value in Table 4. There must be a gap between the hub flange and the flywheel with installation is complete. **Do not over-torque. Do not attempt to close gap between hub flange and flywheel.**

Hub Size	Capscrew Size	Torque ft-lbs. (Nm)
SF	3/8 – 16	30 (40.7)
E (std)	1/2 - 13	60 (81)
F	9/16 – 12	75 (101)

Table 4 – Flywheel Hub Torque Values

6. Ensure that the radial and axial runout values at the rim do not exceed the following values:
Radial O.D. Runout: 0.016 in. (0.4046 mm)
Axial Rim Runout: 0.021 in. (0.5334 mm)
7. Ensure that the compressor flywheel guard is properly installed before operation. The guard must not contact moving parts.

V-BELT DRIVES

Most Blackmer compressors are driven via V-belts which must be properly aligned and tensioned.

1. Lay a straight edge along the face of the motor sheave and compressor flywheel.
2. Adjust either as needed to provide alignment.
3. Tighten the V-belts such that they are taut, but not overly tight. Moderate thumb pressure should deflect each belt about 1/4 – 3/8 in. (6 – 10 mm). Consult your V-belt supplier for specific values.
4. Check the belt tension after 24 - 48 hours run-in. Recheck the tension periodically, and tighten the belts as required.

Caution should be used to avoid overtightening belts, which can shorten bearing and belt life. Belts should be inspected periodically for signs of excessive wear and replaced if necessary.

SEAL ARRANGEMENTS

The seal arrangement type is noted by the 6th digit of the compressor's ID Number on the nameplate. Refer to the section 'SEAL REPLACEMENT' for seal arrangement drawings.

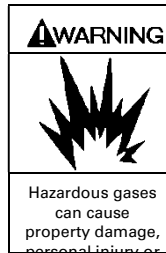

Improper seal installation could release explosive gas to the atmosphere creating an explosion hazard, possibly causing severe personal injury or death.

Hazardous gases can cause property damage, personal injury or death

Seal Type A

The crosshead guide casting includes four 1/4" NPT openings into the distance piece area. This is the area separating the upper and lower sets of packing. The upper openings should only be used after consulting the factory.

The lower distance piece openings may be used to drain any oil/condensate that might accumulate in the distance piece. If used, a normally closed valve must be fitted in the drain line. Opening the valve will result in some product leakage. Only one opening need be used.

INSTALLATION

**Figure 6 -
Typical Compressor
Package**

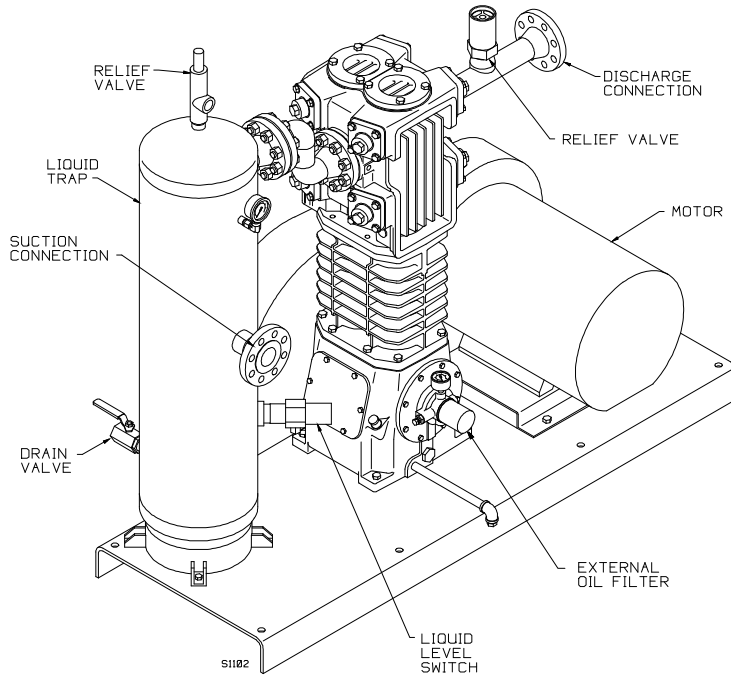

RELIEF VALVES

A relief valve of a type, material and pressure rating suitable to the installation, **MUST** be installed. The relief valve shall be installed in the discharge line between the compressor head and the first block valve.

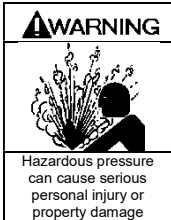

Compressor operating against closed valve can cause system component failure, personal injury or property damage.

Since all systems differ in design, care must be taken to ensure the relief valve is installed to safely vent away from sources of ignition and personnel. This can be accomplished by either orientation or a pipe away, consult the Relief Valve manufacture for assistance.

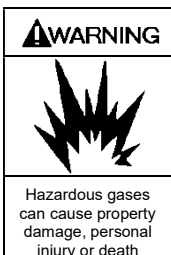

Operation of the relief valve can release explosive gas to the atmosphere creating an explosion hazard, possibly causing personal injury or death

Should the Relief Valve actuate, the cause **MUST** be determined and corrected before continuing operations. See the 'Troubleshooting' section.

PRESSURE GAUGES

Install pressure gauges in the discharge and inlet lines to verify actual suction and discharge pressures.

LIQUID TRAPS

Compressors handling gases that contain condensates or other liquids **MUST** be protected from entry of the liquid. Liquid can also enter the compressor from the discharge piping, particularly if the piping slopes down toward the compressor. To prevent liquid from entering the compressor and causing major damage, it is necessary to carefully consider the system design and have strict procedures for operation.

NOTICE: Liquid in the compressor cylinder can cause destruction of the compressor.

Suction liquid traps collect liquid entrained in the suction gas stream, preventing it from entering the compressor. The most common liquid trap is an ASME code vessel (approx. 12" diameter X 50" tall) fitted with an internal stainless steel mist pad, a relief valve, a manual drain valve, and one or two electric float switches. This type trap is needed if level gauges or automatic drain systems are to be used.

If the liquid level rises too high in the trap, a float switch is tripped, sending a signal to stop the compressor or sound an alarm. The trap must then be drained before the compressor can be restarted. The cause of the high liquid level should be found and the problem corrected.

INSTALLATION

TEMPERATURE SWITCHES

Excessive discharge temperature is a leading cause of premature component failure and is often an early warning sign of impending problems.

Optional temperature switches should be installed with a thermowell as close to the compressor discharge as possible. The switch should be set to actuate at a temperature just above the maximum operating temperature of the compressor.

ATEX compliant compressors **must** have a temperature switch installed.

LOW OIL PRESSURE SWITCHES

Loss of crankcase oil pressure is a rare occurrence, but can result in costly damage. An optional low oil pressure switch set at about 15 psig (1 bar-g) may be installed to shut down the compressor in the event of a lubrication failure. A 10 second delay timer should be used to lock the low oil pressure switch out during compressor startup.

PRESSURE SWITCHES

Pressure switches may be installed in the suction or discharge gas stream as protective devices, for compressor control, or for other uses varying with each application and system design.

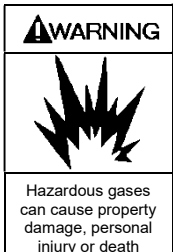

Optional liquid trap level switches, temperature switches, pressure switches or other electrical devices must be properly specified for applications using explosive gases.

SUCTION VALVE UNLOADERS (Optional)

Compressors may be fitted with suction valve unloaders to provide loadless start or capacity control functions. Blackmer unloaders are basically a piston and a plunger atop the suction valve. When pressure is applied to the top of the unloader piston, it and the plunger move downward, pushing the suction valve off its seat and unloading the compressor. When the pressure signal is removed, the unloader spring pushes the piston and plunger back up and the suction valve will resume normal operation.

1. In order for the unloaders to function, the unloader pressure must be at least 30 psi (2.1 Bar) above suction pressure.
2. Do not operate unloaders for longer than 10 minutes as gas recirculation through the suction valves will cause overheating.

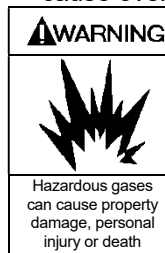

Excessive gas recirculation using suction valve unloaders can be a source of ignition in explosive atmospheres causing severe personal injury or death

3. Do not place a restrictive device such as a back check valve in the suction line near the compressor. If such a device must be installed, the volume in the piping between the device and the compressor must be at least 10 times the cylinder swept volume.

OPERATION

PRE-STARTUP CHECK LIST

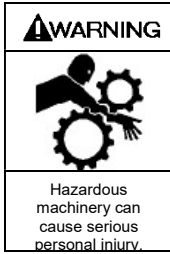

Failure to disconnect and lockout electrical power or engine drive before attempting maintenance can cause severe personal injury or death

1. After the compressor is installed in the system, a complete leak test **MUST** be performed on both the compressor and the piping.

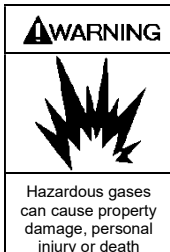

Failure to properly leak test the compressor installation may result in leakage of explosive gas to the atmosphere creating an explosion hazard, possibly causing severe personal injury or death.

2. Re-check the system piping and the piping supports to ensure that no piping loads are being placed on the compressor.



Discharge piping surface temperatures may be hot during operation (over 158°F, 70°C). Temperatures should be monitored and adequate warnings posted.

3. If V-belt driven, check the alignment of the motor and the compressor sheaves. The faces of the sheaves must be parallel.
4. Ensure that pressure gauges are installed on both inlet and discharge of the compressor.
5. Blackmer compressors are shipped from the factory without oil in the crankcase. Fill with a high quality non-detergent oil of the proper viscosity via the compressor nameplate opening. See "Crankcase Lubrication" in this manual.
6. Check the electrical connections for proper wiring, grounding, etc.
7. With the power disconnected, remove the compressor nameplate. Squirt oil onto each crosshead while rotating the compressor by hand to verify smooth operation.
8. Ensure that all guarding is properly installed.

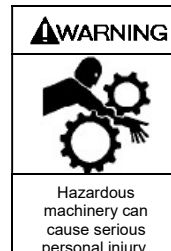

Operation without guards in place can cause serious personal injury, major property damage or death.

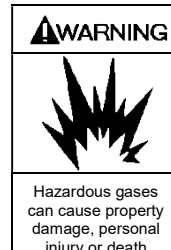

Flywheel guard contact with moving parts may be a source of ignition in explosive atmospheres causing severe personal injury or death

STARTUP PROCEDURE

NOTICE:

Consult the 'Troubleshooting' section of this manual if difficulties during startup are experienced.

1. Start the compressor. Oil pressure should register 25 psig (1.7 bar-g) within 10 seconds.

If proper oil pressure is not present, stop the compressor and correct the problem.

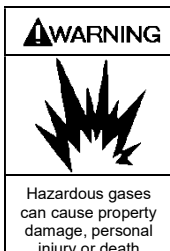

Operation of the compressor with low or no oil may result in extreme temperature in the crankcase. This could be an ignition source in the presence of explosive gas and could lead to severe personal injury or death.

Operating the compressor with low oil pressure will cause severe damage to the unit. See "Setting the Oil Pressure" in this manual.

The oil pump on these models will operate in either direction of crankshaft rotation.

2. Verify that the suction and discharge pressures are within the expected ranges.

Operating limits listed in the "Compressor Data" section must not be exceeded.

3. Check for leakage from the piping and equipment, and repair as necessary.
4. If the seals (packing) have just been replaced, or if the compressor has been out of service for over 6 months, the lower seal **MUST** be manually lubricated during the first 60 minutes of operation. See "Seal (Packing) Replacement" section. New compressors have had the packing broken in at the factory.
5. On newly rebuilt units, the valve hold down screws, valve cover plate bolts and cylinder head bolts **MUST** have their torque checked after 60 minutes running time. Also re-tighten all hold down bolts, flywheel bolts, etc. after 60 minutes running time. See the "Bolt Torque." table.

MAINTENANCE

⚠ DANGER



Flammable gas can cause death, serious personal injury or property damage

Flammable gas and/or liquid can form explosive mixtures with air causing property damage, serious personal injury or death

⚠ WARNING



Hazardous pressure can cause serious personal injury or property damage

Failure to relieve system pressure prior to performing compressor service or maintenance can cause serious personal injury or property damage.

⚠ WARNING



Hazardous machinery can cause serious personal injury.

Failure to disconnect and lockout electrical power or engine drive before attempting maintenance can cause severe personal injury or death

⚠ WARNING



Hazardous voltage. Can shock, burn or cause death.

Failure to disconnect and lockout electrical power before attempting maintenance can cause shock, burns or death

⚠ WARNING



Hazardous or toxic fluids can cause serious injury.

If handling hazardous or toxic fluids, system must be flushed and decontaminated, inside and out, prior to performing service or maintenance

⚠ WARNING



Hazardous pressure can cause serious personal injury or property damage

Disconnecting fluid or pressure containment components during compressor operation can cause serious personal injury, death or major property damage

⚠ WARNING



Hazardous gases can cause property damage, personal injury or death

Explosive gas can cause property damage, personal injury, or death.

⚠ CAUTION



Extreme Heat can cause personal injury or property damage

Extreme heat can cause personal injury or property damage

⚠ DANGER



H₂S atmospheres can cause serious personal injury or death.

H₂S atmospheres can cause serious personal injury or death.

NOTICE:

Blackmer compressor service and maintenance shall be performed by qualified technicians only. Service and maintenance shall conform to all applicable local and national regulations and safety standards.

BOLT TORQUE FOR MODEL NG942B, NGS942 LBS-FT (Nm)

Connecting Rod Bolt	Bearing Carrier	Bearing Cover Plate	Crankcase Inspection Cover	Crosshead Guide	Oil Pump Cover	Cylinder	Head
45 (61.0)	30 (40.7)	40 (54.2)	7 (9.5)	40 (54.2)	12 (16.3)	40 (54.2)	40 (54.2)
Piston Nut	Valve Assembly Nut	Valve Cover Plate	Valve Hold Down Screw	Packing Box Hold Down Ring	Upper Packing Box Screw	Flywheel Hub Bolt	
60 (81)	10 (13.6)	35 (47.5)	120 (163)	75 (102)	50 (68)	see Table 4	

Table 7 - Bolt Torque

MAINTENANCE

SERVICE SCHEDULE

	Daily	Weekly	Monthly	6 Months	Yearly
Overall Visual Check	X				
Check Crankcase Oil Pressure	X				
Check Suction Pressure	X				
Check Discharge Pressure	X				
Drain Distance Piece		X			
Drain Liquid From Accumulation Points		X			
Clean Compressor Cooling Fins		X			
Check Crankcase Oil Level *			X*		
Check Mounting and Anchor Bolts			X		
Check V-Belt Tension			X		
Change Oil and External Oil Filter *				X*	
Check Inlet Filter/Strainer Element				X	
Inspect Valves				X	
Lubricate Motor Bearings per Manufacturer's Suggestions				X	
Inspect Motor Starter Contact Points					X

* Change oil every 1,000 hours of operation, or every 6 months which ever occurs first. If the oil becomes dirty or diluted, change oil and external filter as often as needed to maintain clean oil.

Table 5 - Service Schedule

TOOL LIST

Description	Used For:
Blackmer Wrench 798017	Valve Hold-down Ring Torque Tool
Blackmer Packing Installation Tool 790540	Rod-packing protection during installation.
3" Adjustable Spanner with 1/4" pins (Blackmer PN 790316)	Lower Packing Box Hold-down Ring
15/16" socket with 4" extension	Piston Nut
3/4" End Wrench	Cylinder and Crosshead Guide
1-1/16" Wrench or Socket	Valve Caps
Allen Wrenches: 3/16", 1/4", 3/8"	Valves
Sockets: 7/16", 1/2", 9/16", 5/8", 3/4", 7/8"	Various
Internal Snap Ring Pliers	Seal Replacement
Feeler gauges or Depth Micrometer	Piston Clearance
Screwdriver, Flat Blade	Nameplate screws, Packing Installation
Pliers	
Rubber Mallet	
Arbor Press	Wrist Pin Removal
Bearing Puller	Crankshaft Bearings
Torque Wrench	Various
Hoist (useful)	Cylinder and Crosshead Guide

Table 6 - TOOL LIST

MAINTENANCE

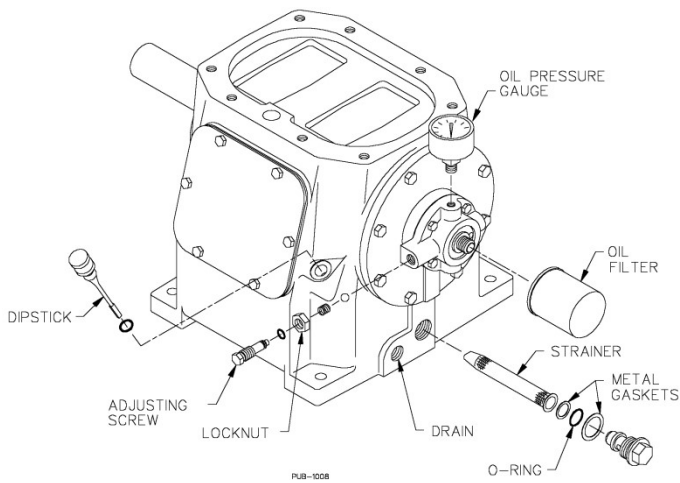

Figure 7 - Compressor Lubrication System

CRANKCASE LUBRICATION

Change the crankcase oil every 1,000 hours or 180 days, whichever is shorter. Under severe dusty, sandy or wet operating conditions, the oil should be changed every 500 hours or every 90 days.

If the crankcase oil becomes contaminated or diluted due to gas leakage past the packing seals, the oil must be changed more frequently. In such cases, change the packing seals as soon as possible.

Non-detergent oils are recommended. Detergent oils can be used providing the gas being handled does not react with the detergent in the oil. If using a detergent oil, be sure there is not a compatibility problem. Ammonia, amine and imine gases are known to react with many of the detergents in oil.

The oil used, detergent or non-detergent, should be of high quality such as API grade SJ, SL, SM, SN or similar.

API grade SA, SB, SC or similar oils should never be used. Recycled oils should never be used.

Synthetic oils are acceptable; use the same guidelines as mineral based lubricants. Consult factory for special lubricating requirements.

Before changing the oil, bring the compressor up to normal operating temperature. Remove the crankcase drain plug and drain the oil into an adequately sized container. Remove the oil pickup screen and clean in a suitable solvent. When reinstalling the pickup screen, inspect the metal gasket and the O-ring for damage, replacing as necessary. If equipped, replace the external oil filter. See Figure 7.

Refill the crankcase via the dipstick or nameplate opening. **DO NOT OVERFILL THE CRANKCASE!**

The oil pump on these models will operate in either direction of crankshaft rotation.

Models	Quarts	Liters
NG942B, NGS942B	7	6.62

Table 8 - Oil Capacity

Mineral Based Oil - API Grade SN, SM, SL, SJ

ISO Grade	SAE	Ambient Temperature	Product
100	30	80°F (27°C) and above	Mobil® Rarus 427 or equivalent
46	20	32 to 80°F (0 to 27°C)	
32	10	0 to 32°F (-18 to 0°C)	
22 - 15	5 - 0	Below 0°F (-18°C)	

Synthetic Oil

ISO Grade	SAE	Ambient Temperature	Product
68	20+	Full Range	Mobil® SHC Rarus 68 or equivalent

Table 9 - Oil Viscosity

SETTING THE OIL PRESSURE (see Figure 7)

1. The oil pressure should be about 25 psig (1.73 Barg).
2. Loosen the locknut.
3. Increase the pressure setting by turning the adjusting screw inward, CLOCKWISE.
Decrease the pressure setting by turning the adjusting screw outward, COUNTER-CLOCKWISE
4. Retighten the locknut.

COMPRESSOR DISASSEMBLY

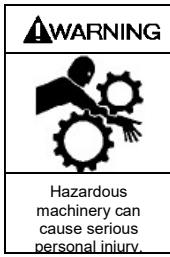

Failure to disconnect and lockout electrical power or engine drive before attempting maintenance can cause severe personal injury or death

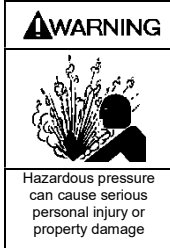

Failure to relieve system pressure prior to performing compressor service or maintenance can cause serious personal injury or property damage.

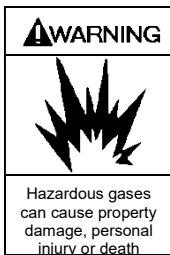

Venting pressure from the compressor piping could release explosive gas to the atmosphere creating an explosion hazard, possibly causing severe personal injury or death.

NOTICE:

Before starting work on the compressor, make sure all pressure is bled off on both the suction and discharge.

1. Remove the head bolts from the head.
2. Remove the head and cylinder head O-rings from the cylinder.
3. Remove the valves per the "Valve Replacement" section.
4. **PISTON REMOVAL**
 - a. Rotate the crankshaft by hand to bring a piston to the top dead center position.
 - b. Remove the piston nut.
 - c. Remove the piston cap using the two 1/4" threaded puller holes. (If two 1/4" bolts are not readily available, the oil pump cover bolts may be used.)
 - d. Remove the upper shims, the piston and the lower shims. Keep the upper and lower shim sets together to simplify reassembly.
 - e. Repeat these steps for the other piston.
5. Remove the cylinder capscrews and lift cylinder from the crosshead guide. Do not allow the upper packing boxes to be lifted off with the cylinder as the packing will be damaged.
6. **PACKING BOX REMOVAL**
 - a. Remove nameplate from the crosshead guide.
 - b. Lift the upper packing box assembly and O-rings off the rod.
 - c. Remove oil deflector ring from the piston rod.
 - d. Remove the lower packing box hold-down ring using a 3" adjustable spanner with 1/4" pins (see 'Tool List' table).
 - e. Place a wooden block (or the end of a mallet handle) through the nameplate opening on top of the crosshead. Rotate the crankshaft by hand until the crosshead pushes the wooden block against the lower packing box, unseating it. **Do not place fingers inside the nameplate opening!**
 - f. Lift the lower packing box assembly and O-ring off the piston rod.
 - g. Repeat the above steps for the packing boxes on the other rod.
 - h. For disassembly of the packing boxes, refer to "Seal (Packing) Replacement."
7. Remove the crosshead guide capscrews, and lift off the crosshead guide and gasket.

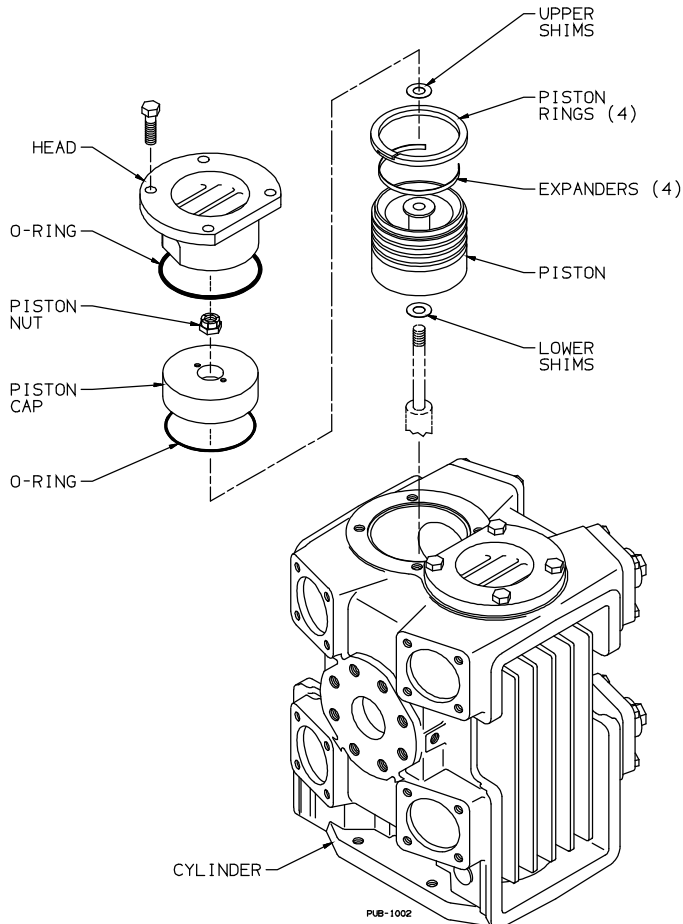

Figure 8 - Cylinder and Piston

COMPRESSOR DISASSEMBLY

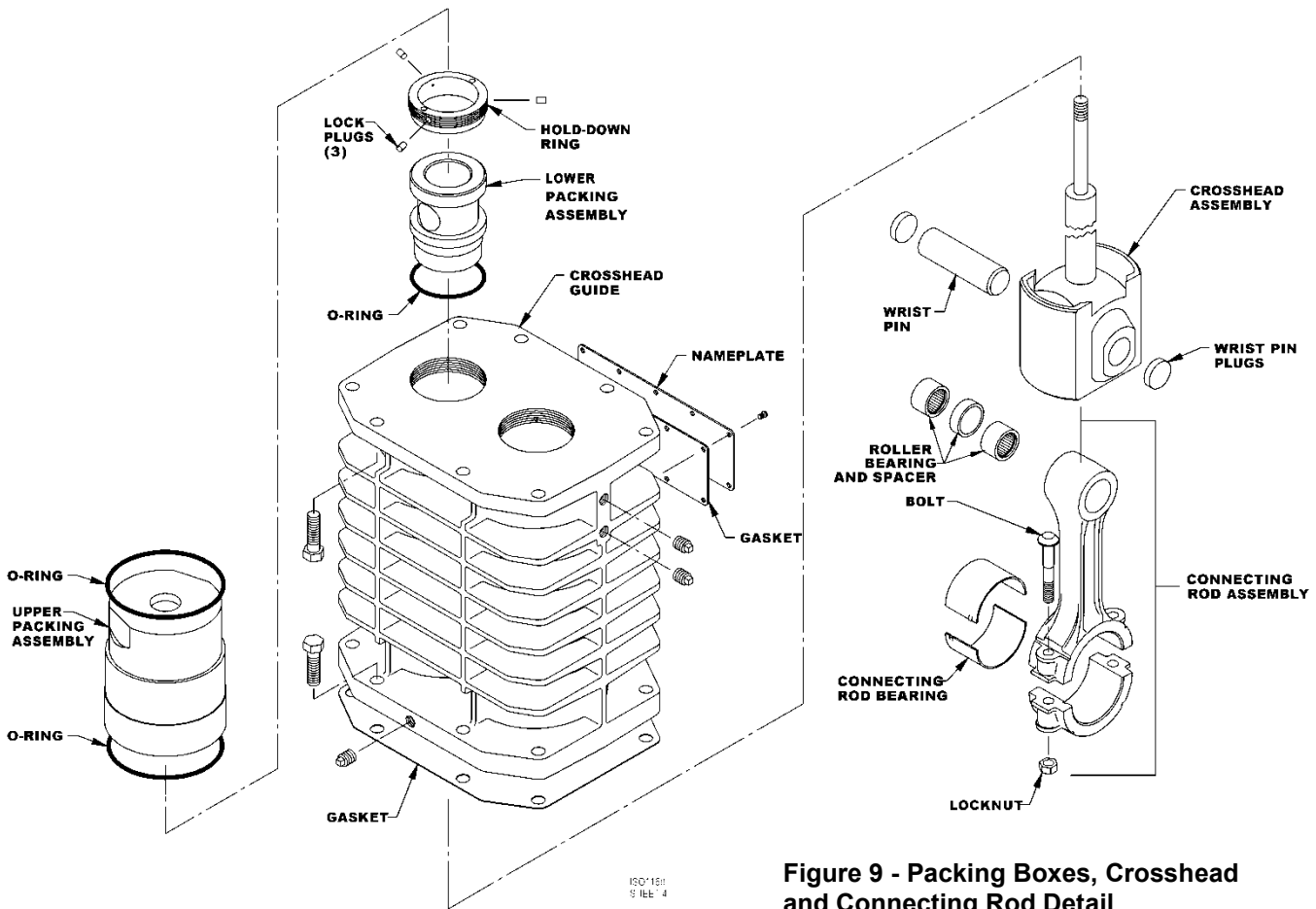

Figure 9 - Packing Boxes, Crosshead and Connecting Rod Detail

8. **REMOVING THE CONNECTING ROD ASSEMBLIES (with the crossheads attached).** The piston rod is permanently attached to the crosshead to form a single assembly. Do not attempt disassembly.
 - a. Drain the oil from the crankcase.
 - b. Remove the inspection plate from the crankcase.
 - c. Remove the locknuts from the two connecting rod bolts. This will release the connecting rod cap (the lower half of the connecting rod) and the two halves of the bearing insert. The connecting rod and the connecting rod cap are marked with a dot on one side so that they can be matched properly when reassembling.
 - d. Lift the crosshead assembly and connecting rod off the crankshaft.

NOTICE: The connecting rod parts are not interchangeable and must be reassembled with the same upper and lower halves. To avoid confusion, work on one connecting rod at a time, or mark the individual halves with corresponding numbers.

9. Remove the opposite connecting rod and crosshead assembly.
10. Rest the crosshead assembly on a bench. Carefully drive the wrist pin and wrist pin plugs out of the crosshead and connecting rod using a suitable pin driver or an arbor press. Removal of the pin releases the crosshead assembly from the connecting rod.
11. If necessary, the wrist pin bearings can be replaced after the crossheads are removed. The small end of the connecting rod is fitted with two roller bearings separated by a spacer. When properly installed, the roller bearings should protrude 0.075" (1.9 mm) on each side of the conrod.
12. To replace the crankshaft bearings, the crankcase must be disassembled, and the crankshaft removed. Refer to "Bearing Replacement" for disassembly instructions.

COMPRESSOR ASSEMBLY

Compressor assembly is generally the opposite of compressor disassembly. Before reassembling, clean each part thoroughly. Check all machined surfaces for burrs or roughness, and file lightly if necessary. **Replace any O-rings or gaskets that are removed or disturbed during service.**

1. CRANKCASE ASSEMBLY

After replacing the crankshaft, bearing carrier, and bearing cover plate, the connecting rod and crosshead can be assembled in the crankcase. See the "Bearing Replacement" section.

- To attach the connecting rod to the crosshead assembly, first coat the wrist pin, the wrist pin bore in the crosshead assembly, and the wrist pin bearing in the connecting rod with grease.
- Start the wrist pin in the bore of the crosshead assembly until the pin begins to project through to the inside of the crosshead assembly. (Use an arbor press if available.)
- Slide the connecting rod up inside of the crosshead assembly and align the bearing with the wrist pin.
- Install the wrist pin through the connecting rod until it is centered in the crosshead assembly. The wrist pin should be snug in the crosshead assembly. The connecting rod should rotate freely on the wrist pin, but should not be loose.
- Dip the wrist pin plugs in grease and press them against the ends of the wrist pin.
- Place the bearing halves into each half of the connecting rod, aligning the bearing tangs with the slots in the connecting rod. Coat the bearing with grease.
- Set the top of the connecting rod over the crankshaft journal. Replace the connecting rod cap with the dots on the connecting rod and cap on the same side.
- Start the nuts on the connecting rod bolts and torque per Table 7 - "Bolt Torque."
- Follow this same procedure for the opposite connecting rod.

2. CROSSHEAD GUIDE

- Place the crosshead guide gasket on top of the crankcase.
- Lubricate the inside bore of the crosshead guide with light oil.
- Set the crosshead guide over the piston rods and the crossheads, and slowly lower it against the crankcase. Make certain that the crosshead assemblies are started straight in the crosshead guide bores to prevent binding when lowering the crosshead guide into position.
- Install the crosshead guide capscrews. **DO NOT** tighten.

3. Fill the crankcase with oil. Refer to the "Crankcase Lubrication" section. Squirt oil into the crankshaft, roller bearings, crankshaft journals, and crosshead assemblies to ensure proper lubrication at start up.

4. Attach the inspection plate and the inspection plate gasket to the crankcase.

5. PACKING BOX ASSEMBLIES

Refer to section 'SEAL REPLACEMENT' for packing box assembly. Before installing the packing boxes, inspect the piston rods for scoring or roughness. Remove any burrs or sharp edges. Lubricate the piston rods, packing and packing box O-rings with light oil. **The packing installation tool (Blackmer Part No. 795040) MUST be used to avoid damaging the packing when starting it over the rod.**

- Place the packing installation tool over the end of the piston rod.
- Install the O-ring on the lower packing box then slide it onto the piston rod and down into the crosshead guide.
- Install the packing box retainer ring, with new nylon locking inserts, and tighten.
- Place the two O-rings on the upper packing box, then slide the box over the piston rod until the upper packing box assembly rests on top of the crosshead guide.

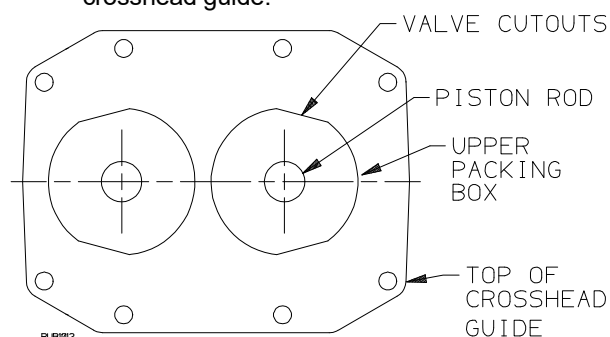

Figure 10 - Upper Packing Box Alignment

- Note the orientation of the valve cutouts on the packing box. The cutouts must align with the valve pockets in the cylinder. Rotate the packing box as needed for the proper alignment.
 - Remove the packing installation tool from the piston rod.
 - Repeat steps a - f for the other piston rod and packing boxes.
6. Rotate the crankshaft by hand a few times, then uniformly tighten the crosshead guide capscrews per the Bolt Torque Table.
7. Packing must be broken in. Finish compressor assembly then refer to "Packing Lubrication."

COMPRESSOR ASSEMBLY

8. CYLINDER ASSEMBLY

- The cylinder should be installed with the valves removed.
 - Set the cylinder on the crosshead guide over the piston rods and packing boxes.
 - Ensure that the valve cutouts on the upper packing boxes are aligned with the cylinder valve pockets.
 - Place the pistons (without shims or rings) on the rods. Rotate the compressor by hand and verify that the pistons are centered in the cylinder bores. The pistons must not touch the cylinder walls. Adjust the cylinder as necessary.
 - Install the cylinder capscrews and tighten evenly per Table 7 - "Bolt Torque."
 - Remove the pistons.
9. Rotate the flywheel by hand to ensure the compressor turns freely.

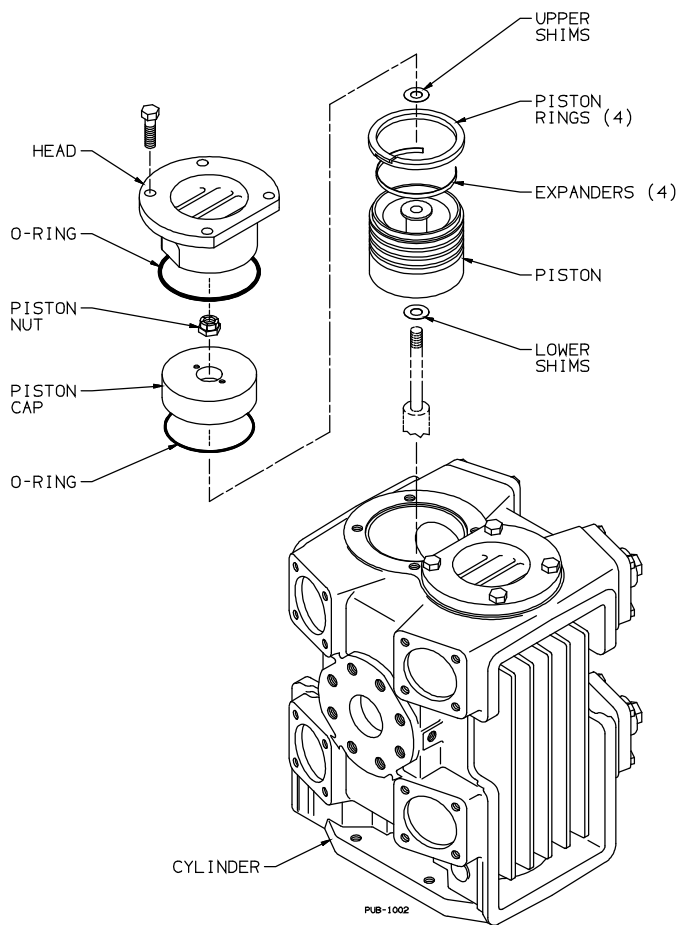

Figure 11 - Cylinder and Piston

10. PISTON INSTALLATION

- To set the piston clearance, remove the valves from one side of the cylinder.
- Rotate the flywheel by hand to bring one piston rod to top dead center.
- Set the bottom shim washer(s) onto the piston rod.
- Place the piston (without rings and expanders) on the piston rod.

- Place the upper shim washer(s) over the rod onto the piston.
- Install the piston cap (without the O-ring).
- Tighten the piston nut on securely.
- Install the head (without the O-ring), and tighten the head bolts securely.
- Ensure that the piston is at top dead center. Measure the clearance between the piston and head through one of the upper valve pockets.
- Rotate the crankshaft until the piston is at bottom dead center. Measure the clearance between the piston and packing box through a lower valve pockets.
- Compare the piston clearance values to those in Table 10 - "Piston Clearance."

Upper Piston Clearance	0.035" - 0.050" (0.89 to 1.27 mm)
Lower Piston Clearance	0.003" - 0.005" (0.08 to 0.13 mm)

Table 10 - Piston Clearance

- Remove the piston. Repeat steps b - k with revised shimming until both clearances values are satisfactory.
 - Once the proper shims are determined, remove the piston again.
 - Install an expander and piston ring in each groove in the piston. The gap in each expander should be 180° from the gap in the piston ring. In addition, each piston ring's gap should be 180° from that of adjacent ring(s).
 - Squeeze the piston rings inward with light pressure and work the piston into the cylinder over the rod.
 - Place the upper shim washer(s) over the rod onto the piston.
 - Install the piston cap and O-ring.
 - Tighten the piston nut per Table 7 - "Bolt Torque."
 - Install the head with its O-ring, and evenly tighten the head bolts per Table 7 - "Bolt Torque."
 - Repeat same procedure for the second piston.
 - Verify the proper upper and lower piston clearance before proceeding.
- Install the valves per "Valve Replacement" Section.
 - Rotate the compressor by hand to verify that it turns freely.
 - Refer to the "Pre-Startup Check List", and "Startup Procedure."
 - After the compressor has run for a sufficient time to reach operating temperature, allow to cool and retighten the valve hold down screws.

VALVE REPLACEMENT

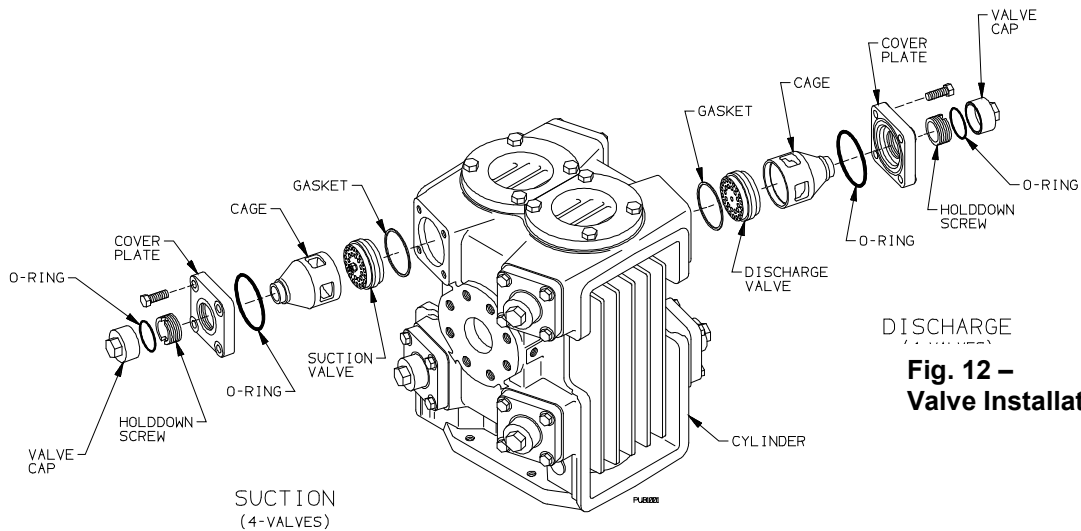

DISCHARGE
**Fig. 12 –
Valve Installation**

WARNING

Hazardous pressure can cause serious personal injury or property damage

Failure to install compressor valves properly can lead to component failure, personal injury or property damage.

WARNING

Hazardous gases can cause property damage, personal injury or death

Failure to install compressor valves properly can result in leakage of explosive gas creating an explosion hazard, possibly causing severe personal injury or death.

WARNING

Hazardous gases can cause property damage, personal injury or death

Failure to install compressor valves properly can result in extreme discharge temperatures. This could be an ignition source in the presence of explosive gas possibly causing severe personal injury or death.

4. VALVE REPAIR

- a. Remove hex nut from valve.
- b. Separate the valve halves and remove springs and plate.
- c. Inspect and replace worn components.
- d. Reassemble valves as shown in the drawing and tighten the valve assembly nut per Table 7 - "Bolt Torque."

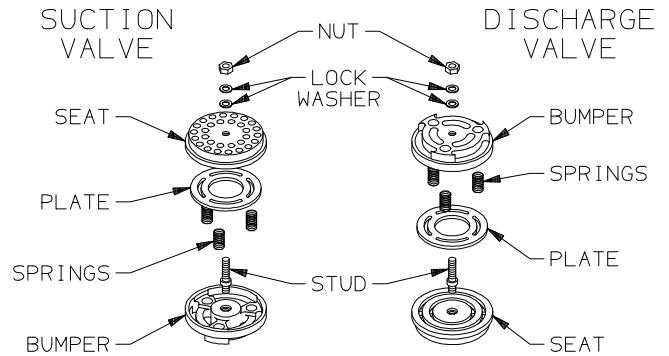

PLB1024
Figure 13 – Valve Details

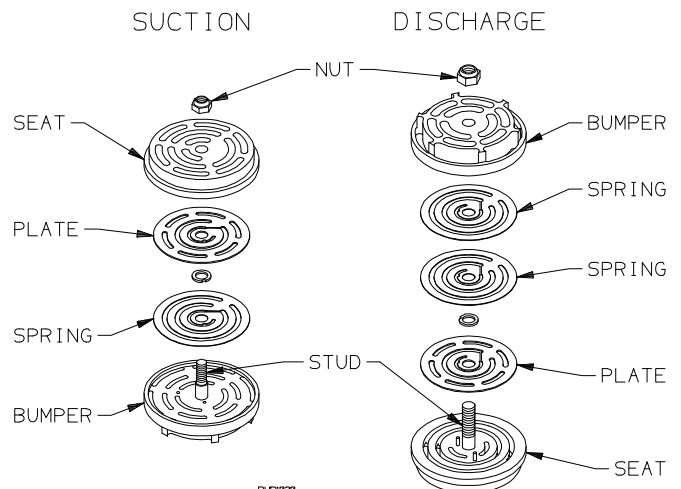

PLB1030
Figure 14 – Stainless Steel Valve Detail

Suction and discharge valves **MUST** be installed in the correct cylinder head locations. See Figure 12.

1. Remove the valve cap and O-ring from each valve.
2. Remove the valve hold down screw with a valve hold-down ring torque tool (see 'Tool List' table).
3. **VALVE REMOVAL**
 - a. Remove the valve cover plate capscrews then lift off the cover plate and O-ring.
 - b. Remove the cage, valve assembly and gasket.
 - c. Inspect the valve for wear or breakage.

VALVE REPLACEMENT

5. VALVE INSTALLATION

The pistons should be installed and the proper piston clearance set **before** the valves are installed.

- a. Remove the old gasket and install a new valve gasket into the cylinder head.
 - b. Install the valve assembly in the cylinder head. Make sure the valve's orientation and location are correct.
 - c. Hold the valve in place with a socket and extension for steps d - f.
 - d. Center the valve cage on the valve assembly.
 - e. Remove the valve hold down screw from the cover plate, then install the valve cover plate with a new O-ring. Tighten the cover plate capscrews according to Table 7 - "Bolt Torque."
 - f. Install the hold down screw and tighten according to Table 7 - "Bolt Torque."
 - g. Install the valve cap and O-ring.
6. After replacing the valves, rotate the flywheel by hand to check for interference between the pistons and the valves.
 7. After 60 minutes of running time, remove the valve cap and retorque the hold down screw. Replace the valve cap and O-ring.

8. UNLOADER SEAL REPLACEMENT

If the compressor is fitted with suction valve unloaders, refer to the parts list page for component identification and location.

- a. Remove the unloader body from the cylinder head (a strap wrench is helpful).
- b. Push the unloader piston out the top of the unloader body.
- c. Inspect and replace the seals as needed - note the seal orientation!
- d. Inspect the unloader body bore - it must be clean and smooth.
- e. Reassemble in the reverse order.

SEAL (PACKING) REPLACEMENT

Two seals separated by a distance piece seal the gas in the cylinder and prevent contamination by the crankcase oil. The upper seal consists of four pairs of segmented packing rings. The the lower seal utilizes a number of PTFE V-rings and an S3R segmented oil seal.

Before starting work on the compressor, note the seal orientation indicated by the 6th digit of the Compressor ID # shown on the compressor's nameplate. Also note any tubing connections in the seal area. See section 'SEAL ARRANGEMENTS'.

1. Follow steps 1 - 6 of "Compressor Disassembly."
2. Upper Packing Box
 - a. Remove the bolts from the bottom of the packing box then remove the packing gland and packing spacer.
 - b. Remove the four packing cups with packing ring pairs and O-rings. If the packing cups are difficult to remove, place a screwdriver blade in the groove in each packing cup and tap *lightly* with a rubber mallet. Do not deform the packing cups or scratch their sealing surfaces.

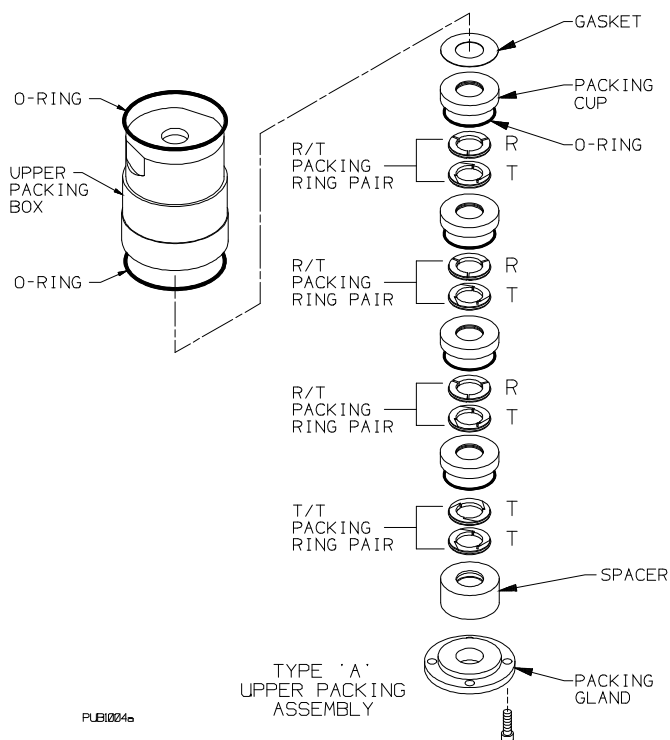

Figure 14 - Upper Packing Assembly

- c. Remove the packing cup gasket.
- d. Clean and inspect all parts, replacing as needed.
- e. Refer to the drawing for the proper orientation of the packing cups and rings. Note: the bottom ring pair differs from the upper three pairs.
- f. Install the gasket and top three packing cups, packing ring pairs and O-rings per the drawing.
- g. Install the bottom packing cup with its O-ring and T/T packing ring pair.
- h. Install the packing spacer and gland, then secure by tightening the bolts evenly.

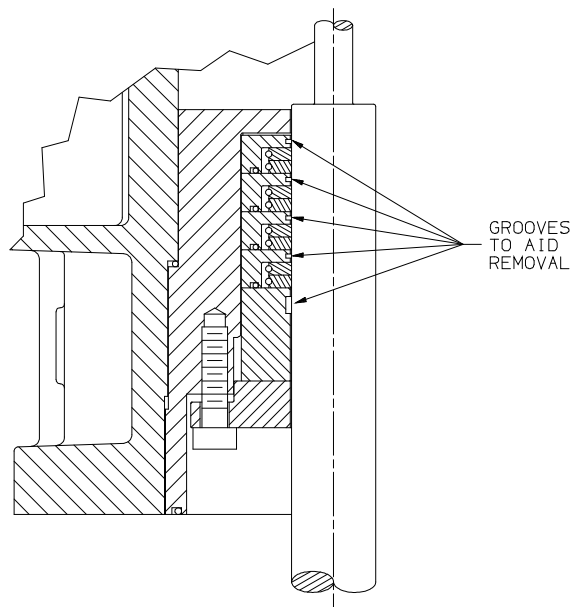

Figure 15 - Upper Packing Section View

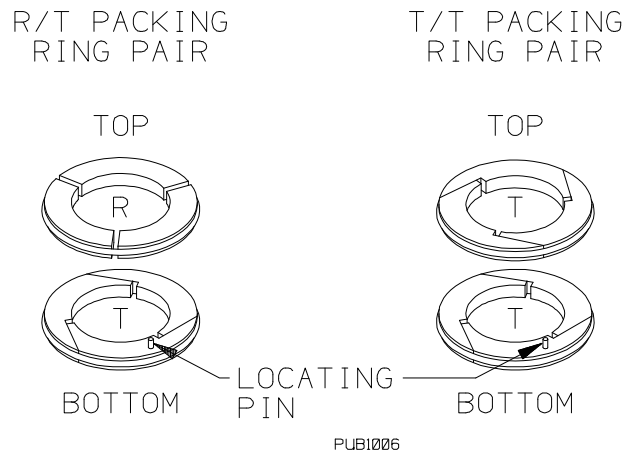

Figure 16 - Upper Packing Detail

3. Lower Packing Box

Disassembly

 - a. Remove the seal cup from the packing box by removing the eight socket head capscrews.
 - b. Remove the retainer ring, spring, packing and washers.
 - c. Remove the remaining two socket head capscrews to remove the seal cup cover.
 - d. Remove the S3R seal from the seal cup.

Assembly

 - e. Clean the seal cup in a suitable solvent. Inspect the bore for wear, roughness, or corrosion.
 - f. Refer to the sketch of the lower packing box for the proper location and orientation of the packing components. Lightly oil the packing rings, then install the packing rings, washers and spring. Install the retainer ring while using the handle end of a screwdriver to compress the packing spring.

SEAL (PACKING) REPLACEMENT

- g. Install the S3R seal in the seal cup as shown in figure 17a. Place the S3R seal on the packing installation tool in the order shown in figure 17b, with the upper segment at the tapered end of the installation tool. Insert the installation tool, with the S3R seal, into the seal cup, with the tapered end toward the packing rings. Place seal cup cover on seal cup and secure with two capscrews
- h. Install the O-ring on the seal cup. Secure the seal cup to the packing box with eight capscrews.

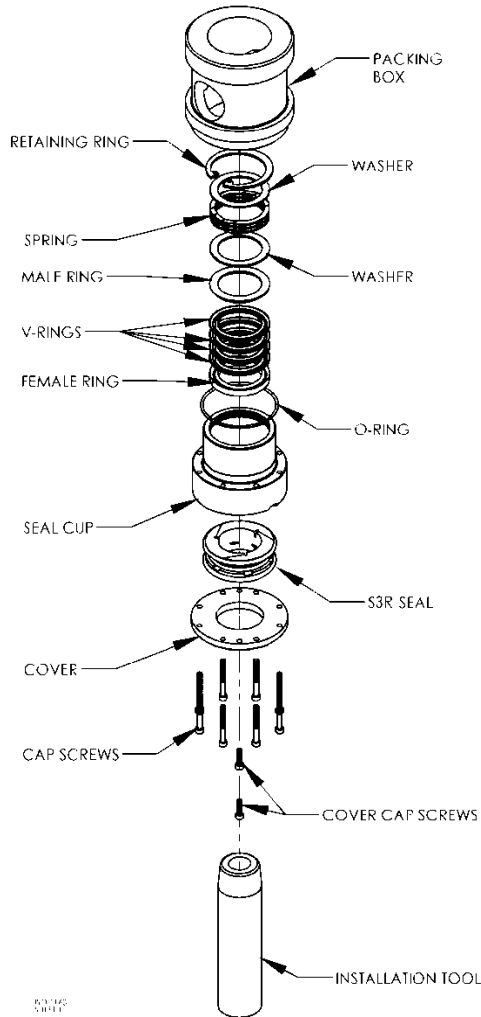

Figure 17 - Lower Packing Assembly

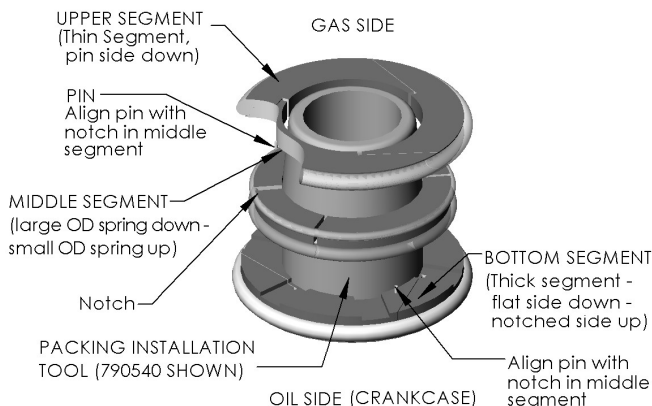

Figure 17b - S3R Oil Seal Orientation

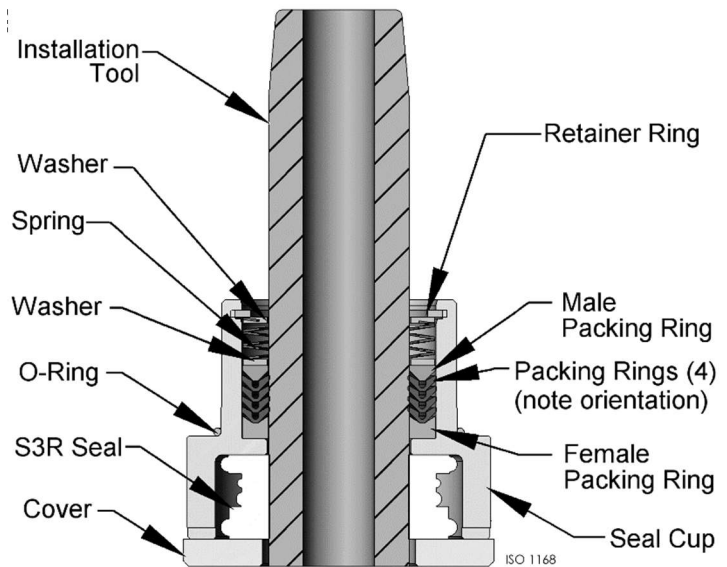
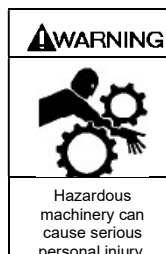
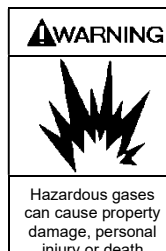

Figure 17a - Seal Cup Assembly

4. Proceed according to steps 5 through 13 of "Compressor Assembly."
5. **LOWER PACKING BREAK-IN**
For maximum packing life, perform the following packing break-in procedure.
 - a. If possible, perform the packing break-in at a lower speed - 400-500 rpm.
 - b. Run the compressor for 5 minutes then **stop** the compressor for 5 minutes to allow adequate cooling of the piston rods.
 - c. (Repeat Step b six times). Using a small oil can, lubricate the piston rod with 3-4 drops of oil each time the compressor is **stopped**. **DO NOT FLOOD THE ROD WITH EXCESS LUBRICANT.**



Do not insert objects or fingers in inspection cavity. Can cause severe personal injury



Improper seal installation could release explosive gas to the atmosphere creating an explosion hazard, possibly causing severe personal injury or death.

BEARING REPLACEMENT

NOTICE:

When replacing the bearings, the entire bearing assembly, including the bearing cup and the bearing cone, must be replaced and the crankshaft endplay must be readjusted.

1. Follow steps 1 through 12 of the "Compressor Disassembly" section.
2. Remove the Oil Pump per the section titled "Oil Pump Replacement."
3. Remove the flywheel.
4. Remove the bearing carrier and gasket from the outboard end of the crankcase. The outboard bearing cup will come off with the bearing carrier and will need to be removed with a bearing removal tool.
5. Remove the key from the crankshaft and slide the crankshaft through the outboard end of the crankcase. The bearing cones can then be removed with a bearing puller.
6. Remove the bearing cover plate from the inboard end of the crankcase. The inboard bearing cup is pressed into the crankcase and can be removed with the use of a bearing removal tool.

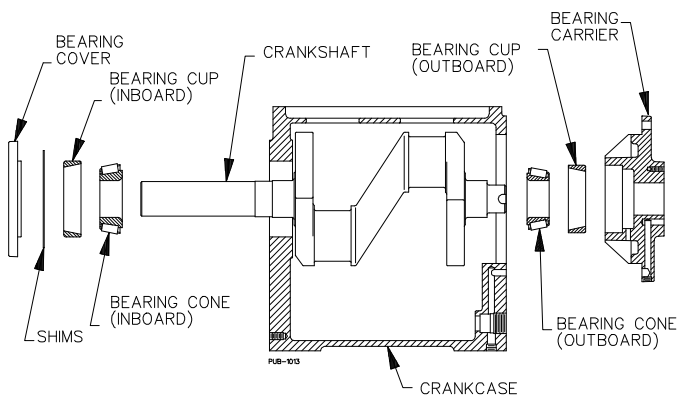

Figure 18 - Bearing Locations

7. To install the bearings:
 - a. Grease the outer edges of the bearing cups.
 - b. Referring to Figure 18 for the proper orientation, carefully press the inboard bearing cup into the crankcase until it is flush with the outer surface of the crankcase.

- c. Note the proper orientation and carefully press the outboard bearing cup into the bearing carrier assembly.
 - d. Press a bearing cone onto each end of the crankshaft with the tapered end outward. The bearing race should rest against the shoulder on the crankshaft.
 - e. Lubricate the bearings with grease.
8. Install the crankshaft through the outboard end of the crankcase.
 9. With the oil pump assembly **removed**, install the bearing carrier and new gasket. The bolt hole positions ensure proper orientation. Tighten the bolts evenly per Table 7 - Bolt Torque."
 10. If the bearings have not been replaced, reinstall the inboard bearing cover plate using the existing shim set. If the bearings have been replaced, use a **thicker** set of shims.
 11. Rotate the crankshaft by hand to verify free movement of the shaft.
 - a. If the crankshaft has an excessive amount of end play, too many shims have been used. Lateral crankshaft movement (end play) between the bearings should be:

End Play at Room Temperature

0.0015 to 0.0030" (0.038 to 0.076 mm)

If necessary, remove shims until the end play is within tolerance.

- b. If the crankshaft binds, or will not turn, not enough shims have been used pushing the bearing cup too tight against the bearing cone. Remove the crankshaft from the crankcase and drive the inboard bearing cup out toward the inboard side of the crankcase. Reinstall the crankshaft and the bearing cover plate using additional shims as required.
12. Install the oil pump per the "Oil Pump Replacement" section of this manual.
 13. Reassemble the compressor according to the "Compressor Assembly" section.

OIL PUMP REPLACEMENT

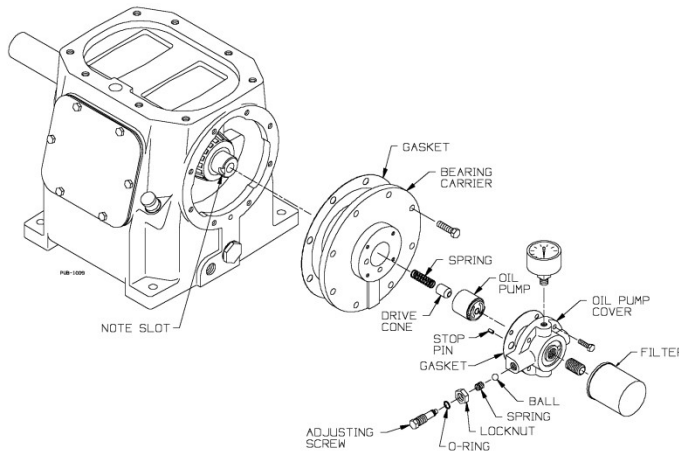

Figure 19 – Oil Pump

1. Remove the oil pump cover bolts and oil pump cover.
2. Remove the oil pump assembly, drive cone and spring.
3. Clean and inspect parts for wear or damage, replace as necessary.
4. Place the spring and the drive cone in the end of the crankshaft.
5. Note the slot in the end of the crankshaft and the drive tab on the back of the oil pump assembly. Install the oil pump assembly into the bearing carrier with the tab and slot aligned.
6. Note the groove around outer edge of the oil pump assembly and the stop pin in the oil pump cover. Position the oil pump cover and new gasket with the pin in the oil pump groove, rotating the oil pump as needed. The bolt hole positions ensure proper orientation of the oil pump cover.
7. BY HAND, tighten the oil pump cover bolts while the pump cover is held flush with the bearing carrier.
NOTICE: If by hand tightening, the oil pump cover cannot be drawn flush with the bearing carrier, the drive tab or the stop pin are improperly aligned. Do not wrench tighten or the oil pump will be damaged.
8. Once the oil pump cover is secured by hand, the bolts may be evenly tightened per Table 7 - "Bolt Torque."

EXTENDED STORAGE PROCEDURES

If a compressor is not to be put into service for some time, or if a compressor is to be taken out of service for an extended period, care must be taken to protect the compressor. The following steps must be taken for both bare compressors and those already piped into a system.

If proper storage procedures are not followed, damage to the compressor may occur. Complete compressor disassembly and replacement of rod packing, bearings and other parts may be required.

1. Keep a written record storage procedures performed – preferably on the unit itself.
2. Fill the crankcase with rust inhibiting oil. (New compressors leave the factory without oil.) Squirt oil on the piston rods and crossheads through the nameplate opening. Loosen the V-belts to relieve the load on the bearings. Rotate the compressor by hand a few times to distribute the oil.
3. Plug all openings and purge the compressor with an inert gas such as nitrogen or **dry** air at about 50 psig (3.5 bar-g). This may be done at the factory if requested. Leave the compressor pressurized to prevent air or moisture from entering the unit.
Check the unit monthly and add additional purge gas as needed.

NOTICE: Tag the unit with a warning that it is pressurized.

4. If a purge gas is not available, fog oil into the compressor suction while rotating the unit. Then plug all openings to keep out moisture, insects, etc.
5. **Turn the flywheel by hand a few revolutions once a month to distribute the oil.**
6. Store the unit under a plastic wrap on its wooden shipping base up off the ground. If the unit was boxed for export shipment, leave it in its box. An indoor or covered storage area is preferable.
7. **Placing the Compressor back in service.**
When the compressor is to be put in service, vent the remaining purge gas and change the crankcase oil. Follow the "Pre-Startup Checklist" and "Startup Procedure" sections in this manual.

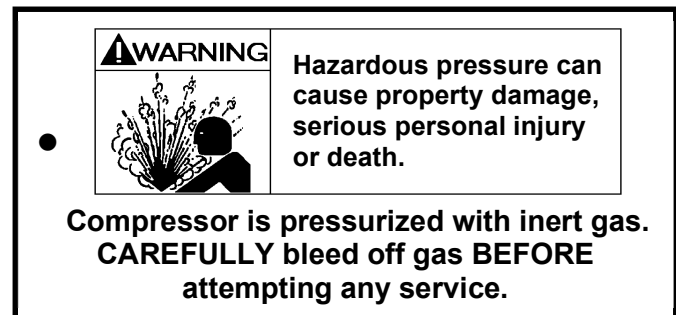
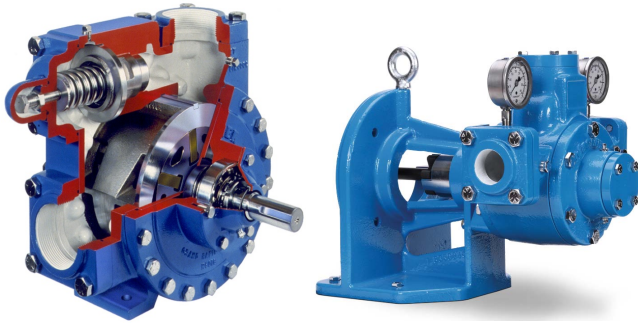

Figure 20 – Pressurized Compressor Tag

TROUBLESHOOTING

PROBLEM	STEP	PROBABLE CAUSE	WHAT TO CHECK	IF PROBLEM STILL EXISTS GO TO STEP ...
Low Transfer Rate	1	4-Way Valve Leaking (when equipped)	Lubricate with a stick lubricant compatible with material being transferred.	2
	2	Worn or Broken Piston Rings	Check condition of rings by restricting discharge line. If pressure increases slowly, rings are probably faulty.	3
	3	Plugged Strainer	Clean screen as necessary.	4
	4	Compressor Valve Faulty	Remove and inspect for broken or worn springs, discs, or bodies. See "Valve Replacement".	5
	5	Compressor Drive Slipping	Tighten belts, check for sheared keys, loose keys or loose flywheel.	6
	6	Piping Improperly Designed or Installed	Use proper pipe sizes.	7
No Flow	7	Excess Flow Valves Slugged	Stop the compressor to let the excess flow open. Installation of a valved bypass line between the suction and discharge lines may be necessary.	3& 4
Knocks or Other Noises	8	Loose Valves	Tighten valve hold-down screws.	9
	9	Worn Internal Parts	Inspect through inspection plates and repair as necessary.	4
No Oil Pressure	10	Oil Pump Relief Valve Not Properly Set.	Set oil pump relief valve.	11
	11	Oil Pump Not Working	Check the Oil Pump drive tab or stop pin for damage.	12
	12	Low Oil Level	Check and fill as necessary	13
	13	Dirty Oil Inlet Strainer	Clean Inlet Strainer	
Gas Leaking from Crankcase Breather	14	Faulty/Worn Packing	Replace Packing.	15
	15	Piston Rod Scored	Replace crosshead assemblies and packing.	16
	16	Improper Seal Arrangement	See "Seal (Packing) Replacement."	---
Relief Valve Actuates	17	Valve Closed Downstream of the Compressor	Open Valve	18
	18	Line Blockage Downstream of the Compressor	Locate Blockage and Correct	---
Shake or Vibration	19	Loose/Broken Mounting or Anchor Bolts	See "Mounting the Compressor Unit"	20
	20	Improper Mounting	Ensure base is supported full length. See "Mounting the Compressor."	21
	21	Improperly Aligned V-belt Sheaves	See "V-Belt Drives"	22
	22	Improperly Installed Flywheel	See "Compressor Flywheel"	23
	23	Nonfunctioning Valves	Replace or repair valves.	---



Sliding Vane Pumps: 5 to 2200 GPM
 Refined Fuels, Liquefied Gases, Solvents, Process



Stainless Steel Sliding Vane Pumps
 1 to 265 GPM: Acids, Brines, Sugars, Syrups,
 Beer, Beet Juice, Cider, Flavor Extracts, etc.

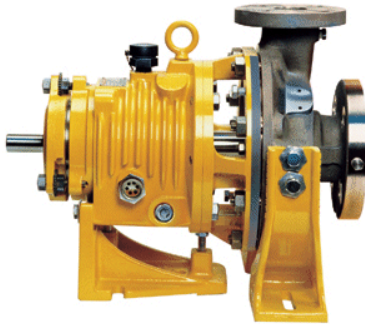

System One® Centrifugal Pumps
 10 to 7500 GPM; Process, Marine

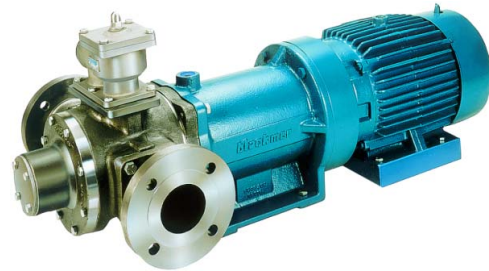

Magnetic Drive Pumps
 Stainless Steel: 14 to 215 GPM

HXL 6, 8 & 10"
 Sliding Vane Pumps
 130 to 2,220 GPM

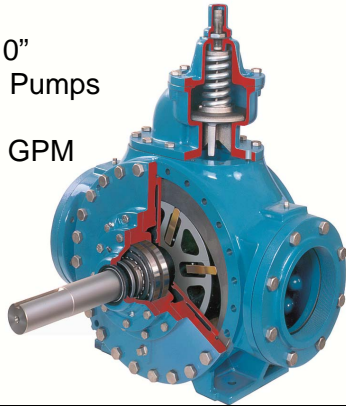

Refineries
 Terminals
 Barges
 Ships



Reciprocating Gas Compressors
 Liquefied Gas Transfer, Boosting, Vapor Recovery



Hand Operated Pumps
 Dispensing, Transfer, In-line



Accessories
 Gear Reducers, Bypass Valves, Strainers

Visit www.blackmer.com for complete information on all Blackmer products



1809 Century Avenue, Grand Rapids, Michigan 49503-1530 U.S.A.
 Telephone: (616) 241-1611 • Fax: (616) 241-3752

E-mail: blackmer@blackmer.com • Internet Address: www.blackmer.com