

# BLACKMER PARTS LIST

## PUMP MODEL: GNX2A, GNXH2A

961423  
Page 1 of 2

**PARTS LIST**  
**101-C01**

Keep with Instructions 101-C00 for Installation, Operation and Maintenance

Section	101
Effective	Sept 2019
Replaces	Mar 2017

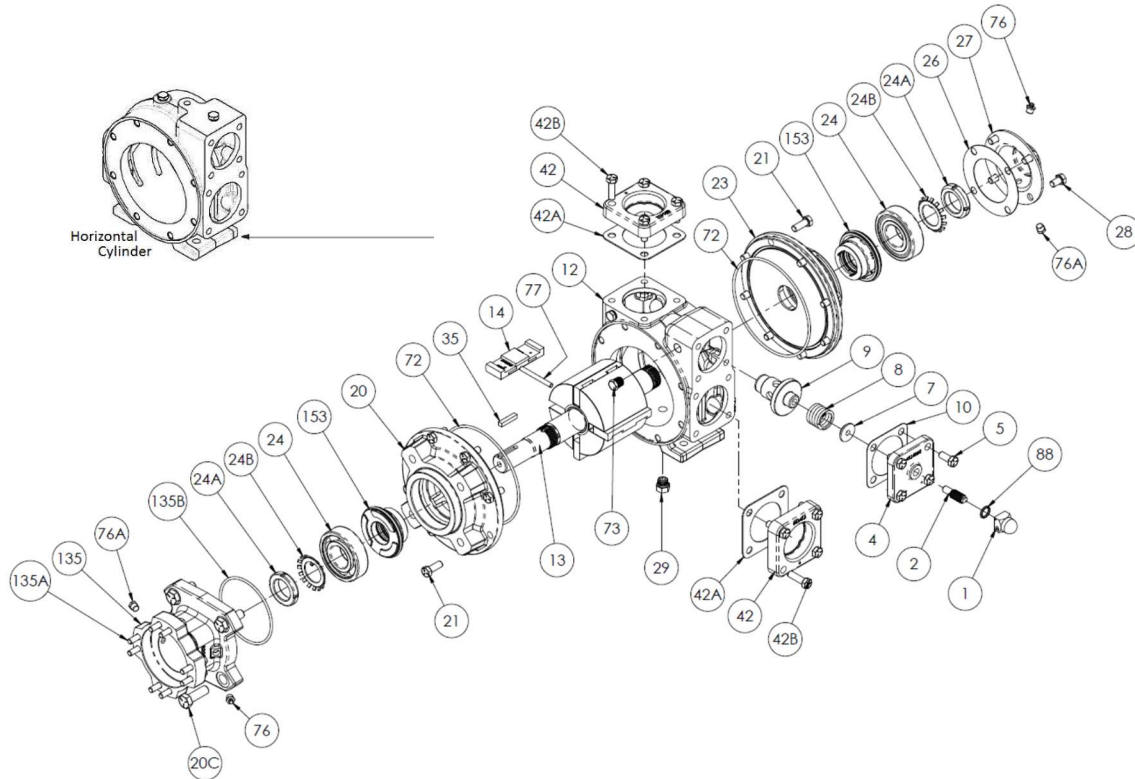

Ref. No.	Description	Parts per Pump	Part No.	Ref. No.	Description	Parts per Pump	Part No.
1	Cap - Relief Valve (R/V)	1	411453	24A	Locknut	2	903521
2	Adjusting Screw - R/V	1	431401	24B	Lockwasher	2	903522
4	Cover - R/V	1	411401	26	Gasket - Bearing Cover	1	<sup>1</sup> 383940
5	Capscrew - R/V Cover	4	920316	27	Bearing Cover	1	041433
7	Spring Guide - R/V	1	423955	28	Capscrews - Bearing Cover	4	920285
8	Spring - R/V (36-50 psi)	1	471415	29	Pipe Plug Assy. (SAE #6), FKM (std.)	0-1	<sup>2</sup> 908212
	Spring - R/V (51-75 psi)		471420		Pipe Plug Assy. (SAE #6), PTFE		<sup>2</sup> 908213
	Spring - R/V (76-110 psi)		471425		Pipe Plug Assy. (SAE #6), Buna-N		<sup>2</sup> 908211
	Spring - R/V (76-110 psi)		471425				
	Spring - R/V (111-125 psi)		471428				
9	Valve - R/V (Std.)	1	451417	42A*	Gasket - NPT Flange (Std.)	2	<sup>1</sup> 381421
	Valve - R/V (Nickel Plated)		451415	42B	Capscrews - NPT Flange (Std.)	8	920351
10	Gasket - R/V Cover	1	<sup>1</sup> 531403	72	O-Ring - Head (FKM) (Std.)	2	<sup>1</sup> 701914
12	Cylinder	1	021403		O-Ring - Head (PTFE)		702242
	Cylinder, w/Drain		021202		O-Ring - Head (Buna-N)		701947
	Cylinder, Horizontal		021435				
13	Rotor & Shaft	1	261426	73	Gage Plug	2	908198
14	Vane - Duravane (Std.)	4	<sup>1</sup> 091419	76	Grease Fitting	1	317815
	Vane - EC Cast Iron		093923	76A	Grease Relief Fitting	1	701992
	Vane - EC Laminate		091429	77	Push Rod	2	<sup>1</sup> 123905
20	Head - Inboard	1	031427	88	Gasket - R/V Cap	1	<sup>1</sup> 701981
20C	Capscrews - Clamp	4	920510	135	Pump Adapter Machining	1	833990
21	Capscrews - Head	16	920331	135A	Hex Head Capscrew (Metric)	8	920028
23	Head - Outboard	1	031425	135B	O-Ring	1	701991
24	Ball Bearing	2	<sup>1</sup> 903156	—	Kit - Maintenance	—	898908

<sup>1</sup> Included in Maintenance Kit

<sup>2</sup> Included in casings with drain hole when applicable.

\* See Page 2 for Weld / ANSI flange options.

SS = Stainless Steel.

EC = Extra-Clearance.

## MECHANICAL SEALS

Ref. No.	Part Name	Parts Per Pump	Part No.
153	Mechanical Seal Complete - <b>(Std.)</b> Cast Iron Stationary Seat, Carbon Seal Face, FKM O-Rings. (IVCV)	2	<sup>1</sup> 331655
	Mechanical Seal Complete - Cast Iron Stationary Seat, PTFE O-Ring, Carbon Seal Face w/ PTFE Seal Ring. (IACT)		331673
	Mechanical Seal Complete - Stainless Steel Stationary Seat, PTFE O-Ring, Carbon Seal Face w/ PTFE Seal Ring. (WACT)		331648
	Mechanical Seal Complete - Cast Iron Stationary Seat, Carbon Seal Face, Buna-N O-Rings. (INCN)		331601
153D	O-Ring - Stationary (FKM)	2	701921
	O-Ring - Stationary (PTFE)		702056
	O-Ring - Stationary (Buna-N)		701934
153L	O-Ring - Rotating (FKM)	2	701980
	Seal Ring - Rotating (PTFE)		**
	O-Ring - Rotating (Buna-N)		701922

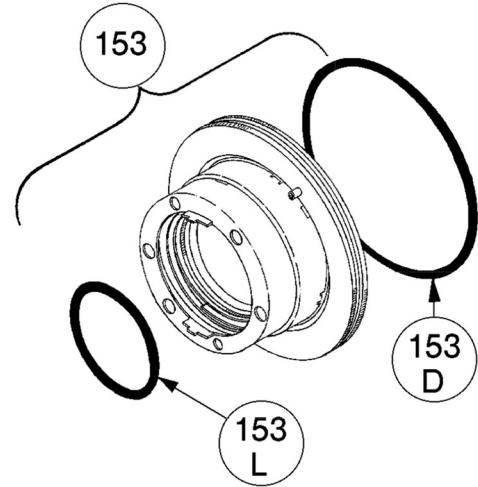

<sup>1</sup> Included in Maintenance Kit

\*\*PTFE Rotating Seal Ring is not available as a separate part.

## FLANGE OPTIONS

Ref. No.	Part Name	Parts Per Pump	Part No.
42	Flange - 2" Weld	2	654405
	Flange - 2" ANSI		651417
42B	Capscrews - Weld / ANSI Flange	8	920384
42C	O-Ring - Weld/ANSI Flg. (FKM)	2	701921
	O-Ring - Weld/ANSI Flg. (PTFE)		702056
	O-Ring - Weld/ANSI Flange(Buna-N)		701934

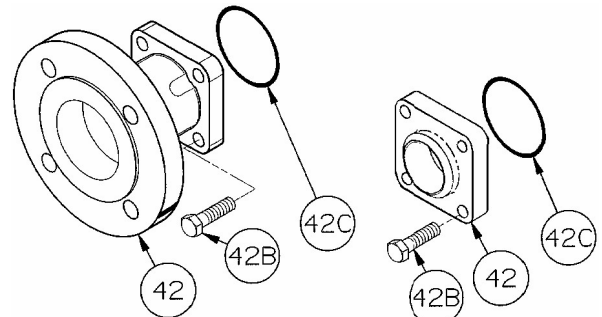

ANSI FLANGE

WELD FLANGE

