



**INSTRUCTIONS 1401-E00 e**

Section	1401
Effective	October 2018
Replaces	February 2017

Original instructions

## ***Check and relief valve for screw compressors***

### ***MISTRAL - B600 - TYPHON II***

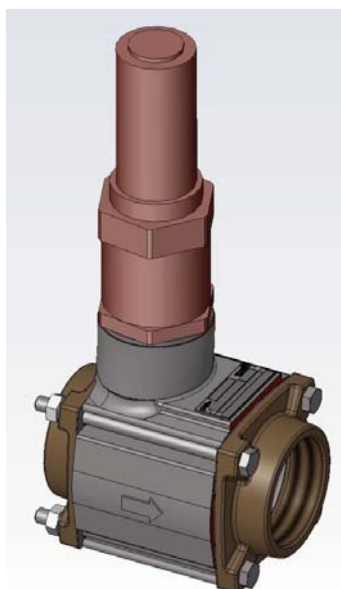

***INSTALLATION***

***OPERATION***

***MAINTENANCE***

**WARRANTY :**

Check and relief valve for MISTRAL - B600 - TYPHON II are covered 24 months by warranty within the limits mentioned in our General Sales Conditions. In case of a use other than that mentioned in the Instructions manual, and without preliminary agreement of MOUVEX, warranty will be canceled.



Z.I. La Plaine des Isles - F 89000 AUXERRE - FRANCE  
Tel. : +33 (0)3.86.49.86.30 - Fax : +33 (0)3.86.49.87.17  
contact@mouvex.com - www.mouvex.com

Your distributor :

# MOUVEX SCREW COMPRESSORS

## SAFETY, STORAGE, INSTALLATION, OPERATION AND MAINTENANCE INSTRUCTIONS

### MODEL : CHECK AND RELIEF VALVE

#### Definition of safety symbols



This is a SAFETY ALERT SYMBOL.

When you see this symbol on the product, or in the manual, look for one of the following signal words and be alert to the potential for personal injury, death or major property damage.



Warns of hazards that **WILL** cause serious personal injury, death or major property damage.



Warns of hazards that **CAN** cause serious personal injury, death or major property damage.



Warns of hazards that **CAN** cause personal injury or property damage.

#### NOTICE

Indicates special instructions which are very important and must be followed.

	<b>WARNING</b>	
		<b>FAILURE TO SET THE VEHICLE EMERGENCY BRAKE AND CHOCK WHEELS BEFORE PERFORMING SERVICE CAN CAUSE SEVERE PERSONAL INJURY OR PROPERTY DAMAGE.</b>
	<b>Hazardous machinery can cause severe personal injury or property damage.</b>	

#### TABLE OF CONTENTS

*Page*

<b>1. OVERALL DIMENSIONS</b> .....	<b>3</b>
<b>2. PRESENTATION OF THE MOUVEX CRV</b> .....	<b>4</b>
<b>3. PRESSURE SETTING AND FLANGES SIZE</b> .....	<b>4</b>
<b>4. INSTALLATION</b> .....	<b>5</b>
<b>5. MAINTENANCE</b> .....	<b>6</b>
<b>6. SPARE PARTS</b> .....	<b>6</b>
<b>7. TROUBLESHOOTING</b> .....	<b>7</b>
<b>8. STORAGE CONDITIONS</b> .....	<b>7</b>
<b>9. SCRAPPING</b> .....	<b>7</b>
<b>10. COMPRESSORS FORM INFORMATION</b> .....	<b>8</b>
<b>11. CERTIFICATE OF CONFORMITY</b> .....	<b>9</b>

Bold numbers following a part description refer to the exploded view reference.

#### REMARKS :

MOUVEX compressors Check and Relief Valve **MUST** be installed in systems designed by qualified personnel. The installation **MUST** be in compliance with local standards, national regulations and rules of safety.

This manual is designed to permit installation and commissioning of MOUVEX compressors Check and Relief Valve and **MUST** accompany the accessory.

Maintenance of MOUVEX compressors Check and Relief Valve **MUST** ONLY be carried out by qualified technicians. This maintenance must meet local and national standards as well as all safety regulations.

Read this manual, including all instructions and warnings, in full **BEFORE** any use of MOUVEX Check and Relief Valve.

# 1. OVERALL DIMENSIONS

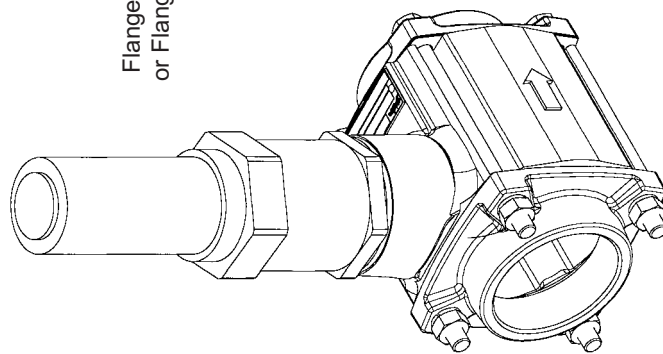
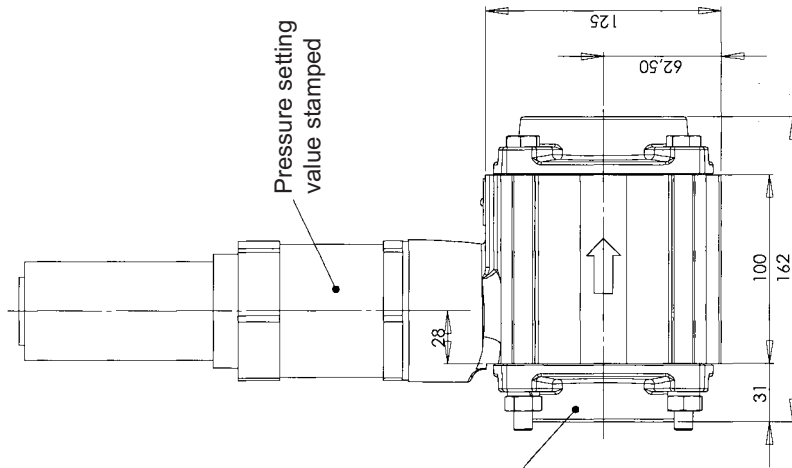
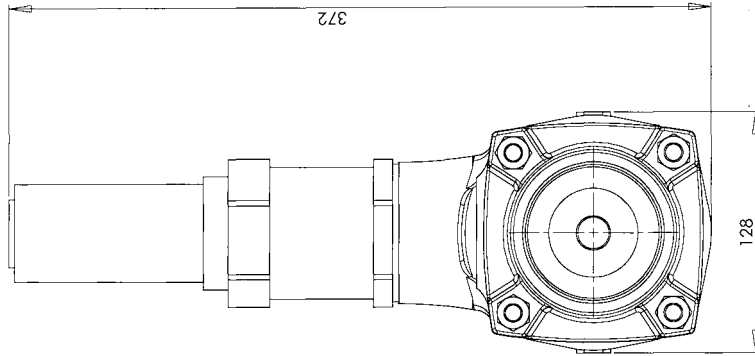

Flange 2,5" BSP  
or Flange 3" BSP

## CHECK AND RELIEVE VALVE

## 2. PRESENTATION OF THE MOUVEX CRV



### PERFORMANCES

Max. flowrate	1500 m <sup>3</sup> /h
Max. flowrate pressure drop	150 mbar
Relief valve adjustment range	2, 2,3 & 2,5 bar
Max. variation : Crack pressure / Full-flow pressure	0,2 bar

The MOUVEX Check and Relief Valve integrate two functions :

- The check valve prevents product return into the compressor when the compressor stops and the tank is still pressurized.
- The relieve valve is there to protect the compressor against unexpected over pressure under working conditions. The extended use of the relieve valve fully open or partly open as a way to manage to out put flow on the discharge line is not authorized. The running time on the relieve valve is expected to be short less than a minute. When the compressor is in used, if the relieve valve starts to open, you must find the raison for the relieve valve opening and corrected before to continue to use the compressor (check : The circuit valves are open, the line is not blocked, the compressor flow is not to big for the application...).



Both functions are necessary to protect the compressor in operation and prevent hazard from happening.

	<b>WARNING</b>
	<b>UNAPPROPRIATE USE OF THE CHECK AND RELIEF VALVE MAY LEAD TO BODY INJURIES AND PROPERTY DAMAGE. TAMPERING WITH THE SETTING OF THE RELIEF VALVE WILL VOID WARRANTY FOR THE COMPRESSOR, ITS ACCESSORIES AND THE RELIEF VALVE ITSELF. ONLY MOUVEX AND ITS APPROVED DISTRIBUTOR MAY ADJUST, RESET OR TAMPERS WITH A RELIEF VALVE SETTING.</b>
<b>Hazardous pressure can cause personal injury or property damage.</b>	

### REMARKS :



Presence of foreign matter inside a failed screw compressor will void the warranty.

The MOUVEX Check and Relief Valve are ment to be used to protect the compressor only and not the system. As such, the pressure directive requirement applicable to the check relief valve is identical to the requirements of the compressor. Respect maximum pressures allowed depending of the pressure specified in the central Instructions.

	<b>WARNING</b>
	<b>USE OF THE MOUVEX RELIEF VALVE TO PROTECT THE COMPLETE SYSTEM IS PROHIBITED. TO COMPLY WITH THE PRESSURE DIRECTIVE REQUIREMENTS, THE SYSTEM MUST BE PROTECTED BY A CE APPROVED COMPONENT, SET TO OPEN BEFORE THE MOUVEX CRV DURING OPERATION.</b>
<b>Hazardous pressure can cause personal injury or property damage.</b>	



## 3. PRESSURE SETTING AND FLANGES SIZE

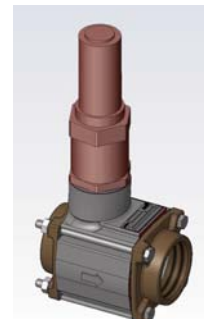

The MOUVEX Check and Relief Valves have 2,5 " or 3" flanges depending on the compressor they will fit on.



	<b>WARNING</b>
	<b>TAMPERING WITH THE SETTING OF THE RELIEF VALVE WILL VOID WARRANTY FOR THE COMPRESSOR, ITS ACCESSORIES AND THE RELIEF VALVE ITSELF. ONLY MOUVEX AND ITS APPROVED DISTRIBUTOR MAY ADJUST, RESET OR TAMPERS WITH A RELIEF VALVE SETTING.</b>
<b>Hazardous pressure can cause personal injury or property damage.</b>	





## 4. INSTALLATION

 <b>WARNING</b>		<b>FAILURE TO RELIEVE SYSTEM PRESSURE PRIOR TO PERFORMING INSTALLATION OR MAINTENANCE OF THE CHECK AND RELIEF VALVE CAN CAUSE PERSONAL INJURY AND PROPERTY DAMAGE.</b>
<b>Hazardous pressure can cause personal injury or property damage.</b>		

 <b>WARNING</b>		<b>FAILURE TO POINT THE END OF THE SAFETY VALVE IN A SAFE DIRECTION MAY RESULT IN PROPERTY DAMAGE AND/OR BODILY INJURIES.</b>
<b>Hazardous pressure can cause personal injury or property damage.</b>		

 <b>WARNING</b>		<b>CONTENT OF THE TANK, PIPING, AND FILTERS MAY BE HAZARDOUS TO HEALTH. TAKE ALL NECESSARY PRECAUTIONS WHEN PERFORMING COMPRESSOR MAINTENANCE.</b>
<b>Hazardous or toxic fluids can cause serious injury.</b>		

 <b>CAUTION</b>		<b>THE CHECK AND RELIEF VALVE WILL BECOME HOT IN OPERATION, EVEN WHEN THE PRESSURE HAS NOT REACHED THE RELIEF SETTING. CONTACT WITH THE CHECK AND RELIEF VALVE MAY LEAD TO PERSONAL INJURIES OR PROPERTY DAMAGE.</b>
<b>Extreme heat can cause injury or property damage.</b>		

The assembly must be mounted at the compressor discharge prior to any other valve and fitting component.

The axis of the air flow must be horizontal with a tolerance of  $\pm 10^\circ$ .

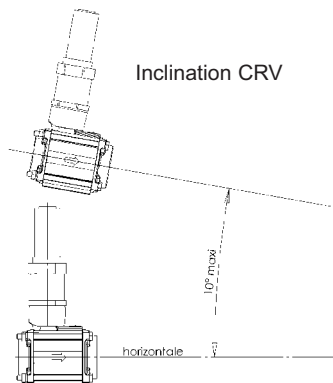

In case of the axis positioned vertically, including a flow direction going upwards, the spring **1805** (see § SPARE PARTS) has to be removed.

### Permitted mounting positions

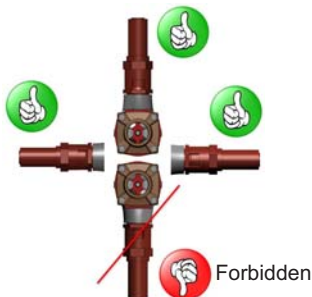

Ensure the arrow cast on the body points away from the compressor.

The Check and Relief Valve must be installed in a location where it is easily accessible and protected from splashes. As it will become hot during compressor operation it should not be located close to temperature sensitive parts. If the location chosen is readily accessible to end users, a warning tag should be located close to the check and relief valve to make them aware of the potential hazard.



Make sure that the piping does not create Mechanical and thermal stress on the Check and Relief Valve port. In particular, as the temperature of the air will increase during deloading, the piping should provide means to release the thermal stress created by the piping thermal expansion.

The valves are factory set and their settings cannot be altered. If you require a new setting, you must order a new valve.

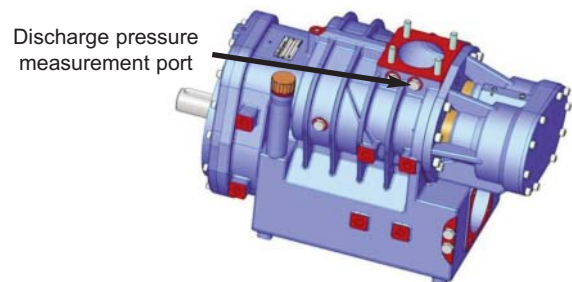
At the end of the installation, a test should be made that the pressure at the compressor outlet does not exceed the maximum limit when the relief valve is fully opened. The sketch below shows the port to use to measure the compressor discharge pressure.



In case the pressure at the outlet port of the compressor exceeds the maximum value set for its rotational speed, the relief valve must be replaced by an adapted relief valve.

 <b>WARNING</b>		<b>TAMPERING WITH THE SETTING OF THE RELIEF VALVE WILL VOID WARRANTY FOR THE COMPRESSOR, ITS ACCESSORIES AND THE RELIEF VALVE ITSELF. ONLY MOVEX AND APPROVED DISTRIBUTOR MAY ADJUST, RESET OR TAMPER WITH A RELIEF VALVE SETTING.</b>
<b>Hazardous pressure can cause personal injury or property damage.</b>		

## 5. MAINTENANCE

### Every month :

- Check adjustment of the relief valve :  
When closing the circuit at compressor discharge, the compressor flange pressure must not exceed the values recommended in the central Instruction, depending on the minimum speed of rotation of the compressor. The measure will be taken on the port referenced (D+E) on the outlines drawings.  
The discharge circuit is to be closed gradually in order to detect any drift in adjustment before subjecting the compressor to pressures that are too high.
- Remove the check valve and make sure that the valve operates freely.

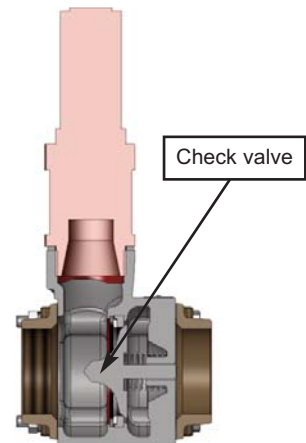

### Check The pressure of opening of the safety valve :

When closing the circuit at compressor discharge, the compressor flange pressure must not exceed the values specified in the Central Instructions.

Remove the check valve and make sure that the valve operates freely.

## 6. SPARE PARTS

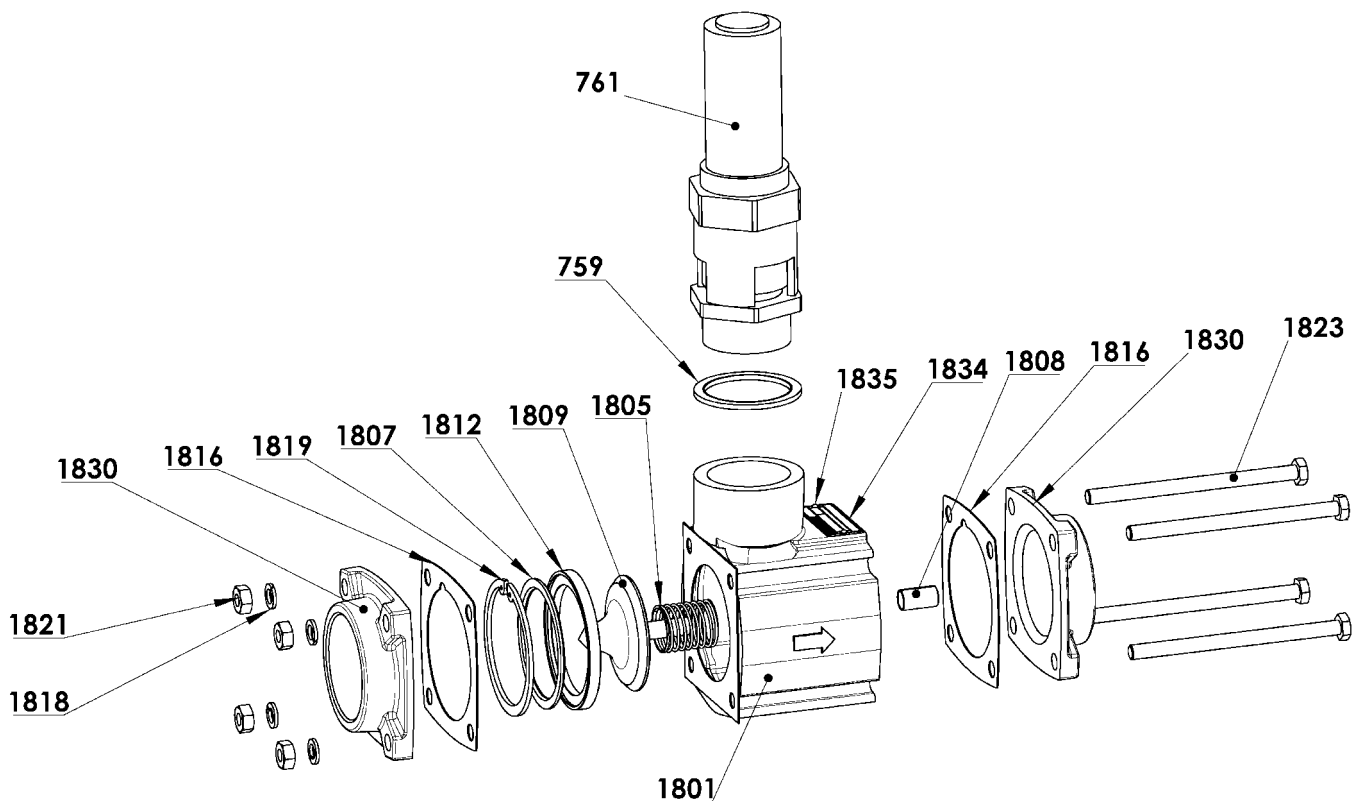

Replacement of a valve kit by an equivalent spare kit may be performed by any end-user, without any modification to the warranty period.

1. Unscrew the safety valve **761**.
2. Check the BS ring **759**, if it is damaged replace the BS ring.
3. Take care to remove any part into the casting aluminum body filet.
4. Screw the new safety valve **761**.

## 7. TROUBLESHOOTING

**CAUTION :**  
OBSERVE ALL SAFETY WARNINGS CONTAINED IN THIS MANUAL.

SYMPTOM	PROBABLE CAUSE / SOLUTION
<p><b>The relief valve leaks when the tanker pressure is below normal operating pressures and the compressor discharge pressure is in line with the manual.</b></p> <p style="text-align: center;"><b>CAUTION :</b></p> <p>In the event that the pressure drops between the compressor and the tanker increase (clogging of the filter, clogging of the pipes, etc.) it is normal for the relief valve to open in order to protect the compressor.</p> <p>A Prior to investigating the causes below, it is essential for pipes, filters and other components located between the compressor and the tanker to be checked for clogging.</p> <p>See causes 1, 2, 6, 7, 9, 10.</p>	<ol style="list-style-type: none"> <li>1. There is a massive pressure drop between the compressor and the relief valve =&gt; Resolve the pressure drop problem (cleaning, moving the relief valve etc.).</li> <li>2. The pressure sensor is faulty =&gt; check its calibration.</li> <li>3. The check valve is jammed in the open position =&gt; check the parts 1801, 1808 and 1809. Replace if necessary.</li> <li>4. Deterioration of leak tightness between the seat 1812 and the check valve =&gt; check the state of the parts. Replace if necessary.</li> <li>5. The check valve return spring 1805 is faulty =&gt; change the spring.</li> <li>6. Leak between the relief valve and the pipe =&gt; check the seals 1816 and the flanges 1830. Check the tightening of the screws 1818, 1821, 1823. Replace if necessary.</li> <li>7. The compressor body 1801 is no longer leak tight =&gt; replace the body.</li> <li>8. Part 1812 has come out of its recess =&gt; replace the parts 1807, 1812 and 1819.</li> <li>9. Relief valve damaged =&gt; change relief valve.</li> <li>10. The check valve 1809 is jammed in the closed position =&gt; check the parts 1801, 1808 and 1809. Replace if necessary.</li> </ol>
<p><b>Product present upstream from the relief valve.</b></p> <p>See causes 3, 4, 5, 7, 8.</p>	
<p><b>The compressor discharge pressure is not in line with the manual when the relief valve is opened.</b></p> <p>See causes 2, 6, 9.</p>	

NB : The valve must be reset by a MOUVEX approved service centre prior to being put back into operation following any maintenance operation requiring the pressure setting seal to be broken.

## 8. STORAGE CONDITIONS

The equipment must be systematically stored in an area sheltered from bad weather.

If installation is interrupted, put back in place the original protective components or equivalent components.

The equipment must bear its original protective components until it is installed in its final application.

## 9. SCRAPPING

The check and relief valve must be scrapped in compliance with the regulations in force.



# 10. COMPRESSORS FORM INFORMATION

Before any material return, it is required to get an authorization from MOUVEX.

	<b>COMPRESSORS FORM INFORMATION</b>																													
MOUVEX After Sales Department Z.I. La Plaine des Isles 89000 AUXERRE - FRANCE	Tel : (33) 3 86 49 86 03 Fax : (33) 3 86 49 86 48	Date : Followed by : File :																												
In order to properly deal with the return material, please fill in this form.																														
<b>A – Name and address of user</b> _____ _____ Person to contact : _____ Phone Nr : _____																														
<b>B – Name and address of installer</b> _____ _____ Person to contact : _____ Phone Nr : _____																														
<b>C - Material's serial number</b> _____		<b>D - Starting up date</b> _____																												
Running time estimation _____ hours																														
<b>E - Installation details</b>	<b>F - Operating parameters</b>																													
Please tick the appropriate boxes :																														
<table border="1" style="width: 100%; border-collapse: collapse;"> <thead> <tr> <th style="width: 15%;"></th> <th style="width: 10%;">20R</th> <th style="width: 10%;">30R</th> <th style="width: 10%;">13R</th> <th style="width: 10%;">15L</th> <th style="width: 10%;">19R</th> <th style="width: 10%;">22L</th> </tr> </thead> <tbody> <tr> <td>B600</td> <td></td> <td></td> <td></td> <td></td> <td></td> <td></td> </tr> <tr> <td>MISTRAL</td> <td></td> <td></td> <td></td> <td></td> <td></td> <td></td> </tr> <tr> <td>TYPHON II</td> <td></td> <td></td> <td></td> <td></td> <td></td> <td></td> </tr> </tbody> </table>		20R	30R	13R	15L	19R	22L	B600							MISTRAL							TYPHON II							<input type="checkbox"/> Compressor's speed <span style="float: right;">_____</span> <input type="checkbox"/> Operating pressure <span style="float: right;">_____</span> <input type="checkbox"/> Motor speed (tachometer) at the time of the incident <span style="float: right;">_____</span> <input type="checkbox"/> PTO ratio <span style="float: right;">_____</span> <input type="checkbox"/> Product transfered _____ _____ _____	
	20R	30R	13R	15L	19R	22L																								
B600																														
MISTRAL																														
TYPHON II																														
Valve setting : _____ bar																														
<b>G - Suction conditions</b>																														
<input type="checkbox"/> Air connection on truck chimney <input type="checkbox"/> Direct air connection <input type="checkbox"/> Flexible pipe between filter and compressor <input type="checkbox"/> Inox pipe between filter and compressor																														
<b>H - DESCRIPTION OF THE FAILURE</b>																														
<input type="checkbox"/> Blocking <input type="checkbox"/> Leakage <input type="checkbox"/> Noise, vibration <input type="checkbox"/> Other _____ _____ _____																														
I - Has the machine been replaced by a new one ? If yes which is the serial number		_____																												
J - Has the machine been replaced by a removed one ? If yes which is the serial number		_____																												
<b>K - Remarks and comments of the user about the problem :</b>																														
_____ _____ _____																														
Please send us back this completed form by fax or E mail as quick as possible.																														

rév.16/10/2013





# DECLARATION UE DE CONFORMITE EU CERTIFICATE OF CONFORMITY – EU KONFORMITÄTSERKLÄRUNG



MOUVEX sas, ZI La Plaine des Isles – 2 Rue des Caillottes – 89000 Auxerre France, déclare que l'équipement suivant / declares the following equipment / erklärt, dass folgende Ausrüstung:

Modèle : \_\_\_\_\_ (A) Répondant aux spécifications indiquées dans l'ARC N° : \_\_\_\_\_ (B)  
Designation / Bezeichnung Serial N° / Serien Nr According to the specifications recorded in the acknowledgment of order N°:

Pour la Sté MOUVEX sas, fait à Auxerre le : \_\_\_\_\_  
For Mouvex sas company – Date : \_\_\_\_\_  
Für die Fa Mouvex sas - Datum : \_\_\_\_\_

Responsible Quality Clients  
Customer Quality Manager / Qualitätsbeauftragter

- Configuration : \_\_\_\_\_  
Konfiguration
- Type / Geräteart :
- Pompe à mvt excentré (Eccentric Disc Pump / Ringkolbenpumpe)
  - Pompe péristaltique (Peristaltic Pump / Schlauchpumpe)
  - Pompe centrifuge (Centrifugal Pump / Kreiselpumpe)
  - Compresseur à Vis (Screws compressor / Schraubenverdichter)
  - Compresseur à palettes (Vaness compressor / Flügelzellenverdichter)
  - Refroidisseur Hydraulique (Hydraulic oil cooler / Hydraulikkühler)
- Groupe de pompage / de compression (Pumping Unit / Compressor Unit) (Pumpen- / Kompressoraggregat)
- Pompe à lobes (Lobes Pump / Drehkolbenpumpe)
  - Pompe à palettes (Vaness Pump / Flügelzellenpumpe)
  - Autre pompe (Other Pump / Andere Pumpe)

Est conforme aux dispositions suivantes :

- Directive « MACHINES » 2006/42/CE et aux législations nationales (à transposer, portant sur les dispositifs de sécurité liés aux risques mécaniques et électriques applicables aux machines tournantes.  
NF EN 809:2009 NF EN 1672-2:2009 NF EN ISO 13857:2008 NF EN 12162:2009
- Directive « ATEX » 2014/34/EU du 26 février 2014 et aux législations nationales la transposant; portant sur les appareils destinés à être utilisés en atmosphères explosibles. Conformité obtenue par application des normes :  
NF EN 1127-1:1997 NF EN 13463-1:2009 NF EN 13463-5:2009 Certification ATEX délivrée par INERIS\*, Organisme Certificateur, et portant le marquage suivant : (C)

Is in conformity with the provisions of the following Directive:

- « MACHINES » Directive 2006/42/EEC as transposed by the national legislation, concerning safety equipments and arrangements relative to mechanical and electric risks applicable to rotative machines.  
NF EN 809:2009 NF EN 1672-2:2009 NF EN ISO 13857:2008 NF EN 12162:2009
- « ATEX » Directive 2014/34/EU (26 Feb. 2014) as transposed by the national legislation, concerning equipment intended to be used in explosive atmospheres. Conformity obtained by application of the standards :  
NF EN 1127-1:1997 NF EN 13463-1:2009 NF EN 13463-5:2009 ATEX Certification delivered by INERIS\*, Notified Body, and with the following marking: (C)

den Bestimmungen der nachstehenden Richtlinien entspricht:

- „Maschinen-Richtlinie“ 2006/42/EEC wie umgesetzt im nationalen Recht hinsichtlich der Ausrüstungssicherheit und Sicherheitsvorkehrungen bezogen auf mechanische und elektrische Risiken, die für rotierende Maschinen gelten.  
NF EN 809:2009 NF EN 1672-2:2009 NF EN ISO 13857:2008 NF EN 12162:2009
- „ATEX“ Richtlinie 2014/34/EU (26. Feb. 2014) wie umgesetzt im nationalen Recht in Bezug auf Ausrüstungen für den Einsatz in explosionsgefährdeter Atmosphäre. Die Konformität hat Geltung durch Anwendung folgender Normen:  
NF EN 1127-1:1997 NF EN 13463-1:2009 NF EN 13463-5:2009 Die ATEX-Zertifizierung wurde von der benannten Stelle INERIS\* erteilt, und mit folgender Kennzeichnung: (C)

II G II T Temp Max produit pompé / Max Temp Flow / Max. T° Medium = \_\_\_\_\_ °C (X = voir notice / see IOM / siehe Handbuch)

L'équipement désigné ci-dessus doit impérativement respecter les conditions d'utilisation ATEX décrites dans nos notices d'instruction. Il doit être employé conformément à l'utilisation qui en a été prévue de par sa conception et sa fabrication, et conformément aux normes en vigueur. Nous, soussignés, déclarons que l'équipement concerné est conforme aux Directives listées ci-dessus et aux normes applicables s'y rapportant.

The equipment indicated above must imperatively comply with the ATEX conditions of use described in our instruction book. It must be used according to the foreseen use by its design and its manufacturing, and according to the current standards. We, undersigned, declare that the concerned equipment is in conformity with the Directives listed above and in the applicable standards in force.

Oben stehend bezeichnete Ausrüstung muss unbedingt den in unseren Betriebsanleitungen beschriebenen ATEX Anwendungsbedingungen entsprechen. Sie ist entsprechend dem durch Konstruktion und Fabrikation vorgesehenen Verwendungszweck und entsprechend den geltenden Normen einzusetzen. Die Unterzeichner erklären, dass die bezeichnete Ausrüstung den oben aufgeführten Richtlinien und den diesbezüglich geltenden Normen entspricht.

CTRL-D025 – rév.04 du 25/05/2016 – Déclaration de conformité CE-Atex

\* (INERIS – Parc Techno Alata – 60550 Verneuil-en-Halatte – France).