



INSTRUCTIONS 1401-V00 e

Section	1401
Effective	February 2017
Replaces	March 2016

Original instructions

XL DDIC

Instructions for application

DIRECT DRIVE PACKAGE

TYPHON II

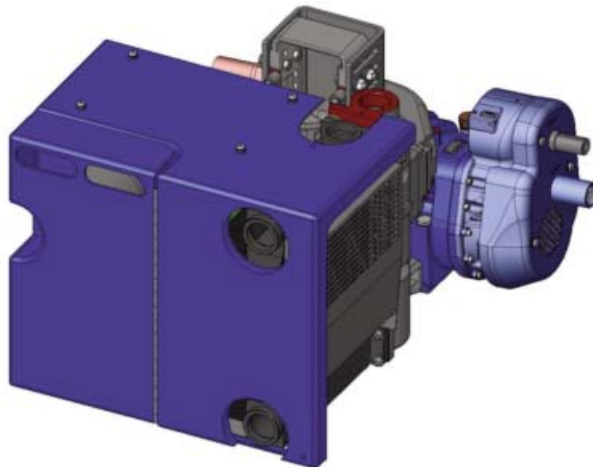

INSTALLATION
OPERATION
MAINTENANCE
SAFETY
STORAGE



This Instruction only contains direct drive package information. It is imperative to have in complement the compressor one and also all the others relatives to the accessories, also the parts list before installing the equipment.



Z.I. La Plaine des Isles - F 89000 AUXERRE - FRANCE
Tel. : +33 (0)3.86.49.86.30 - Fax : +33 (0)3.86.49.87.17
contact@mouvex.com - www.mouvex.com

Your distributor :

MOUVEX TRUCK SCREW COMPRESSOR

SAFETY, STORAGE, INSTALLATION, OPERATION AND MAINTENANCE INSTRUCTIONS

MODELS : XL DDIC

DIRECT DRIVE PACKAGE

TYPHON II

TABLE OF CONTENTS	Page
1. OVERALL DIMENSIONS	4
2. INSTALLATION	6
2.1 Mounting location6
2.2 Mounting procedure6
2.3 At suction7
2.4 Check relief / Safety valve8
2.5 Drive9
2.6 Electric circuit10
2.7 Instrumentation11
2.8 Chair modification11
3. MAINTENANCE	12
3.1 Maintenance schedules12
3.2 Air filter replacement procedure12
3.3 Cartridge replacement procedure12
3.4 Drive train inspection12
3.5 Check valve and relief valve inspection12
3.6 Warranty claims12
4. TROUBLESHOOTING	13
5. STORAGE CONDITIONS	13
5.1 Compressor13
5.2 BSC oil13
6. USE	14
7. SCRAPPING	14
8. COMPRESSORS FORM INFORMATION	15
9. CERTIFICATE OF CONFORMITY	16

Definition of safety symbols



This is a SAFETY ALERT SYMBOL.

When you see this symbol on the product, or in the manual, look for one of the following signal words and be alert to the potential for personal injury, death or major property damage.

DANGER

Warns of hazards that **WILL** cause serious personal injury, death or major property damage.

WARNING

Warns of hazards that **CAN** cause serious personal injury, death or major property damage.

CAUTION

Warns of hazards that **CAN** cause personal injury or property damage.

NOTICE

Indicates special instructions which are very important and must be followed.

REMARKS :

MOUVEX truck screw-type compressors **MUST** be installed in systems designed by qualified personnel. The installation **MUST** be in compliance with local standards, national regulations and rules of safety.

This package is designed to be used on paved roads. Unless, it is necessary to move towards a package DDK to achieve a strengthened and adapted to the situation set.

This manual is designed to permit installation and commissioning of MOUVEX truck screw-type compressors and MUST accompany the compressor.

Maintenance of MOUVEX screw-type compressors must ONLY be carried out by qualified technicians. This maintenance must meet local and national standards as well as all safety regulations. Read this manual, including all instructions and warnings, in full BEFORE any use of MOUVEX compressors.













Reading and the removal of the labels on the package apply to approval.

ADDITIONAL DOCUMENTATION

The table below gives the list of instructions in addition to this application instruction :

XL DDIC application	Instructions	Parts list
TYPHON II 20R/30R	NT 1401-G00	PL 1401-G01 PL 1401-V01
TYPHON II 13R/15L TYPHON II 19R/22L	NT 1401-G00	PL 1401-G01 PL 1401-Q01 PL 1401-V01
Torque limiter	NT 1401-B00	PL 1401-Q01
Check and relief valve	NT 1401-E00	PL 1401-Q01
Oil cooler	NT 1401-AC00	PL 1401-Q01

SAFETY DATA

 WARNING		IT IS IMPERATIVE TO APPLY THE TRUCK PARKING BRAKE AND TO BLOCK THE WHEELS BEFORE ANY INTERVENTION DUE TO RISKS OF SERIOUS BODILY INJURIES OR PROPERTY DAMAGE.
Hazardous machinery can cause severe personal injury or property damage.		
 WARNING		COMPRESSING GASES INTO A VESSEL CONTAINING FLAMMABLE OR EXPLOSIVE GASES OR COMPRESSING FLAMMABLE OR EXPLOSIVE GASES, CAN CAUSE PROPERTY DAMAGE, PERSONAL INJURY OR DEATH.
Hazardous fluids can cause fire, serious personal injury or property damage.		
 WARNING		FAILURE TO INSTALL ADEQUATELY SIZED PRESSURE RELIEF VALVE(S) CAN CAUSE PROPERTY DAMAGE, PERSONAL INJURY OR DEATH.
Hazardous pressure can cause personal injury or property damage.		
 CAUTION		COMPRESSOR, PIPING AND ACCESSORIES WILL BECOME HOT DURING OPERATION AND CAN CAUSE SERIOUS PERSONAL INJURY.
Extreme heat can cause injury or property damage.		
 WARNING		CONTENTS OF THE COMPRESSOR, TANK, PIPING, AND FILTERS COULD BE HAZARDOUS TO HEALTH. TAKE ALL NECESSARY PRECAUTIONS WHEN PERFORMING COMPRESSOR SERVICE OR MAINTENANCE.
Hazardous or toxic fluids can cause serious injury.		
 WARNING		THE NOISE EMITTED BY WORKING MOVEX SCREW COMPRESSOR CAN BE HIGHER THAN 80 DBA. THE END USERS MUST USE, WHEN NECESSARY THE APPROPRIATE EAR PROTECTIONS. FAILURE TO WEAR HEAR PROTECTIONS IN AREAS WHERE THE NOISE IS HIGHER THAN 80 DBA CAN LEAD TO PERMANENT BODY DAMAGE.
A loud noise can cause permanent body damage.		

SAFETY CHECK LIST

1. Before operating the compressor, ensure the vessel to which the compressor is connected is certified to withstand the pressure and /or vacuum produced.
2. Verify adequately sized relief valves have been fitted to protect the vessel. The package is equipped with a vacuum relief valve and with a pressure relief valve in order to protect the compressor. Do not use solvents or inflammable products for cleaning the pipelines and the accessories.
3. Volatile gas Gas/air mixtures which are potentially volatile/explosive must not be introduced or allowed to be introduced into the vacuum pump if volatile vapours are passed through the vacuum pump, adequate flame arresters and protective devices must be fitted. MOVEX will not take any responsibility for the recommendation, performance or the safety of the vacuum pump in these conditions.
4. All pressure vessel and piping connected to the compressor must be isolated and in a safe operating condition.
5. Operators should wear ear protection when operating truck mounted compressors.
6. There are components within the compressor of sufficient weight to cause injury if mishandled. Use proper lifting devices as necessary. Do not attempt to lift the vacuum pump without disconnecting it from the base frame
7. Where necessary, this equipment should be grounded to control static electricity.
8. The temperature of the air leaving the compressor is elevated above ambient due to air compression. Check that the elevated temperatures do not adversely affect the product and any material used in design of the system. Attach clearly marked warning signs to warn of potentially hot surfaces on the compressor, piping and accessories which will burn if touched.
9. Mounting of the compressor must be correctly engineered and the compressor must be properly secured. Refer to the Compressor Mounting section of this manual.

NOTICE :

MOVEX COMPRESSORS ARE DESIGNED TO PRODUCE COMPRESSED AIR. NOT TO PUMP LIQUIDS, LIQUEFIED GASSES OR POWDERS THROUGH THE COMPRESSOR. TO DO SO WOULD VOID THE WARRANTY.

LIFTING POINTS :

The compressor can be picked up from underneath to be transported.

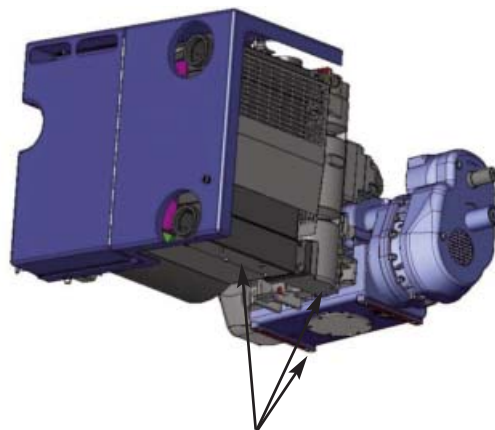

Those areas are acceptable to support the package. Compressor and chair support should be favored.

1. OVERALL DIMENSIONS

TYPHON II 20R - 30R

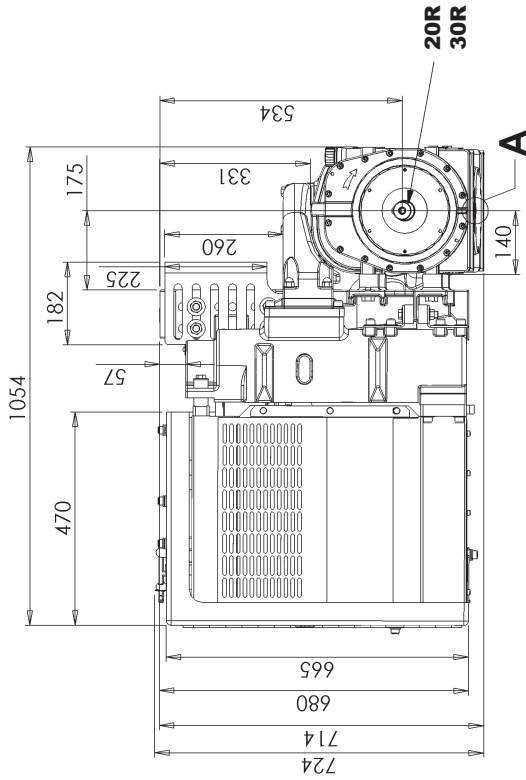
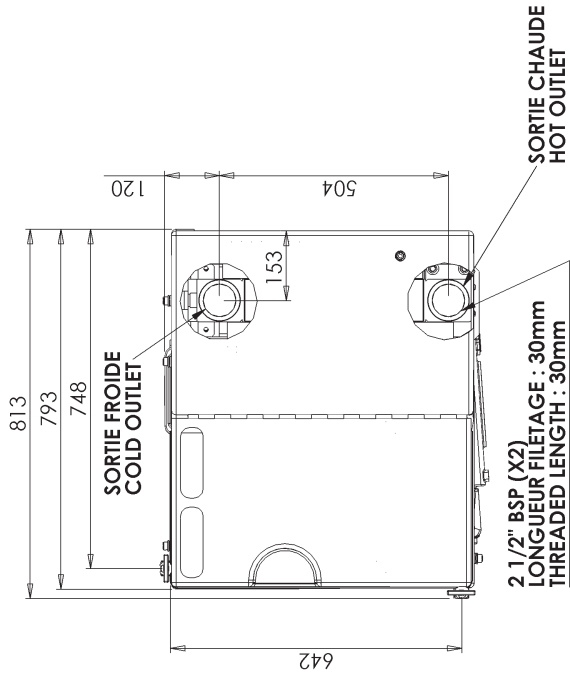

DÉTAIL A

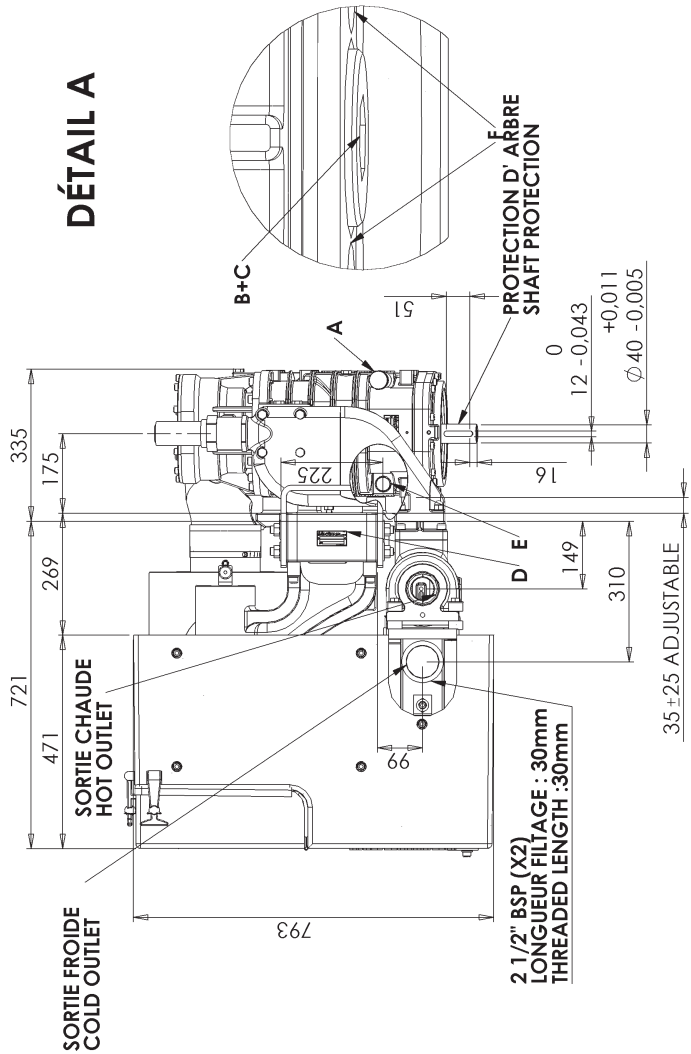

A	Jauge d'huile / Oil gauge
B	Filtre à huile / Oil filter
C	Vidange / Draining cap
D	Plaque signalétique / Identification plate
E	Bouchon 3/4" (pour montage jauge d'huile à droite) 3/4" cap for right oil gauge installation
F	Bouchon magnétique G3/8" / Magnetic plug G3/8"

Poids avec limiteur de couple
Weight with torque limiter :
298 kg

1. OVERALL DIMENSIONS (continued)

TYPHON II 13R/15L - 19R/22L

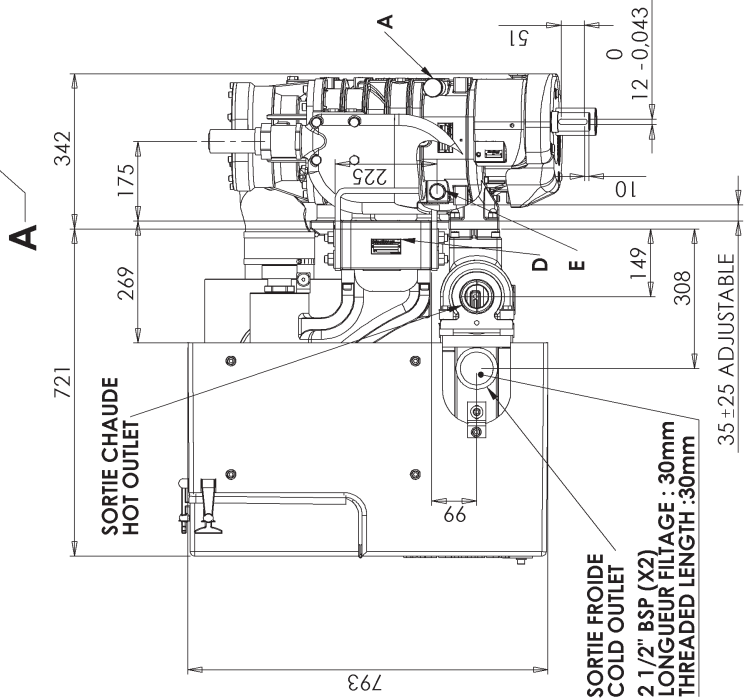
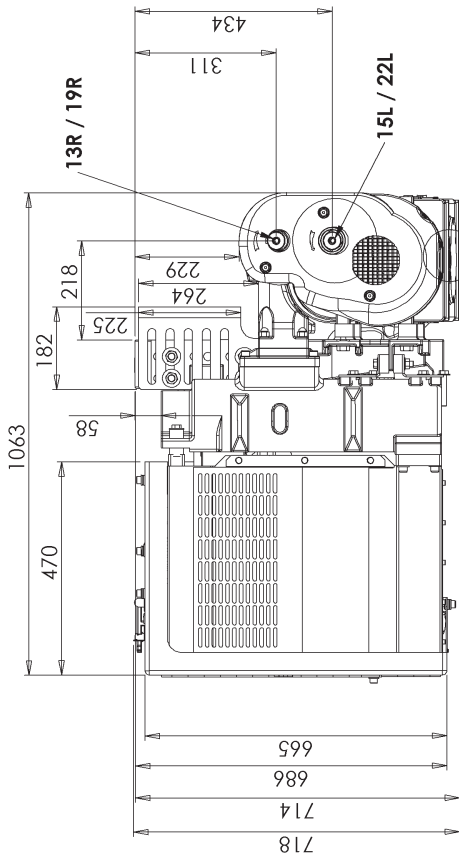
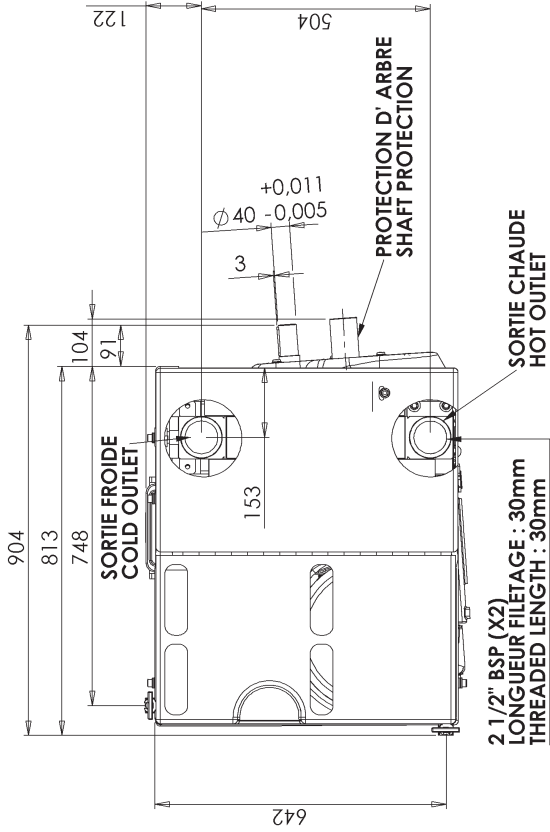

DÉTAIL A

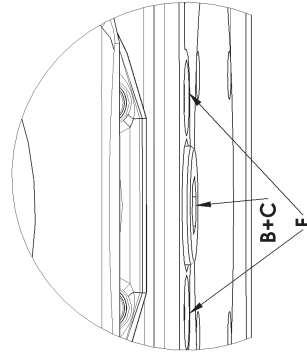

A	Jauge d'huile / Oil gauge
B	Filtre à huile / Oil filter
C	Vidange / Draining cap
D	Plaque signalétique / Identification plate
E	Bouchon 3/4" (pour montage jauge d'huile à droite) 3/4" cap for right oil gauge installation
F	Bouchon magnétique G3/8" / Magnetic plug G3/8"

Poids avec limiteur de couple
Weight with torque limiter :
328 kg

2. INSTALLATION

During the assembly, watch that no foreign body penetrates into the compressor. The suction and discharge pipings must be perfectly clean. Any foreign body risks to damage seriously the compressor.



The presence of foreign bodies in the compressor suction channel is susceptible of leading to serious property damage or serious injuries.

2.1 Mounting location

The compressor must be installed in a location where it is easily accessible. In particular, make sure that the oil filling plug, oil magnetic plugs and the filter are accessible.

The clogging indicator must remain visible to the operator.

Choose a location where the compressor is relatively protected from gravel projections and road spray as well as exhaust fumes and engine heat.

The compressor is mounted on the chair at an angle of 4°. If the chair is mounted vertically, it can be used to adapt to most movements, in other words those which have a gradient of between 3 and 5° inclusive.

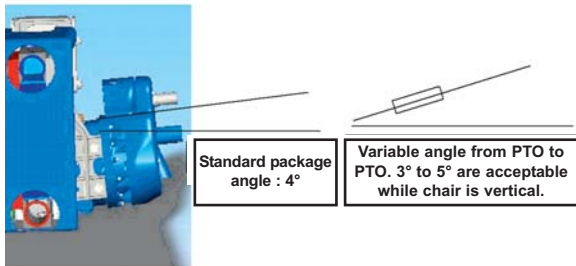

To prevent potential interferences between the package and the truck accessories (mudflap, tank ...) a minimum distance of 5 cm between the package and these accessories must be respected.

To benefit fully from the cooling performance of XL DDIC packages, a minimum distance of 10cm must be respected between the right side of the package and any accessory forming an obstacle to air flow (tank, ...).

5 cm clearance to avoid any contact

10 cm clearance to optimize package outlet temperature

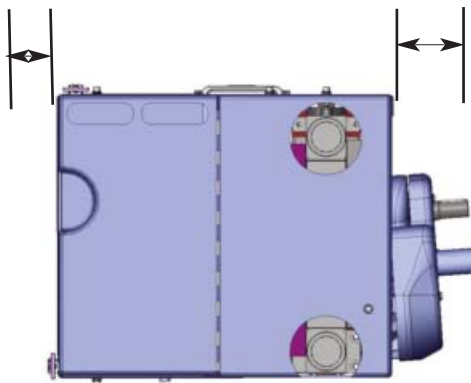

In the same way, a minimum distance of 5 cm must be respected between all accessories located in the chassis (PTO, universal joint....) and the compressor package.

2.2 Mounting procedure

2.2.1 Package handling procedure

Compressors are packaged and fixed onto a pallet. To move and install the package for the first time, the package should be carried on the pallet.

For maintenance operations, the package should be fastened onto a pallet such that the chair is vertical. The areas set aside for fastening the package are the compressor, silencer and the radiator, as shown in the picture below.

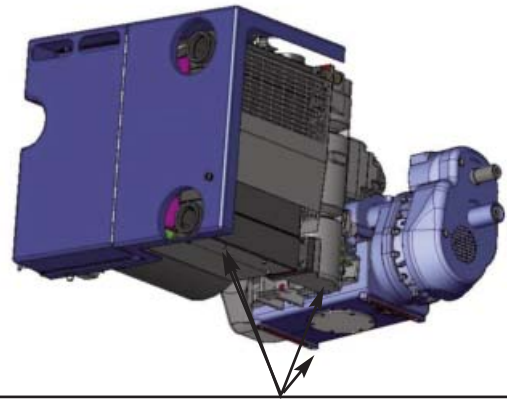

Those areas are acceptable to support the package. Compressor and chair support should be favored.

2.2.2 Package installation procedure

The compressor package is delivered with a special assembly tool. This U comes mounted on the chair.

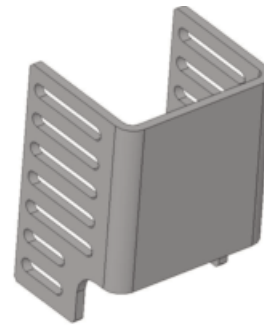

We propose the following assembly procedure :

- Bring the compressor package to the side of the truck using a transpallet or any other suitable equipment.
- Determine the position of the package on the truck as close as possible to its final position.
- Check the universal joint angles and how parallel the compressor shaft and the PTO shaft are.
- Mark on the U the positions of the holes necessary for assembly (use only existing holes on the truck chassis).
- Remove the package from the truck.
- Pierce the U, deburr and clean. To make sure that you do not make the part fragile keep a minimum axle spread distance of 40 mm between 2 holes.
- Mount the U on the truck. The screws must be at least grade.

2. INSTALLATION (continued)

- Use 6 screws Ø 14 mm minimum.
- Bring the package to the truck.
- Mount the package on the U with a minimum of 8 fixing points (4 on each side).
- Remove the pallet and package.
- Check the universal joint angles and how parallel the compressor shaft and the PTO shaft are.
- Mount the universal joint.
- Perform an operating test on the compressor.
- Check with a manometer the pressure at which the valve starts to open.

2.3 At suction

The temperature of the inlet air must not exceed 40°C

Any side protection barriers must be removed EACH time the compressor is used to allow air to reach the compressor suction freely, and move around the cooling circuit.

The installer must check whether there are such protective barriers and that they may be manipulated easily by the driver. It may be desirable to install a system preventing the operation of the PTO if the protection is not removed, to guarantee that the compressor operates under satisfactory conditions.

To prevent the filters from clogging prematurely, the air sucked in must be free of smoke and road dust.

A minimum distance of 600 mm must be left free in front of the filter for their extraction and replacement.

2.3.1 Standard suction

If using a standard package, no precautions need be taken when assembling the package.

2.3.2 Chimney suction

If using a chimney package, the front air inlet will be plugged with a blanking plate which is not included.

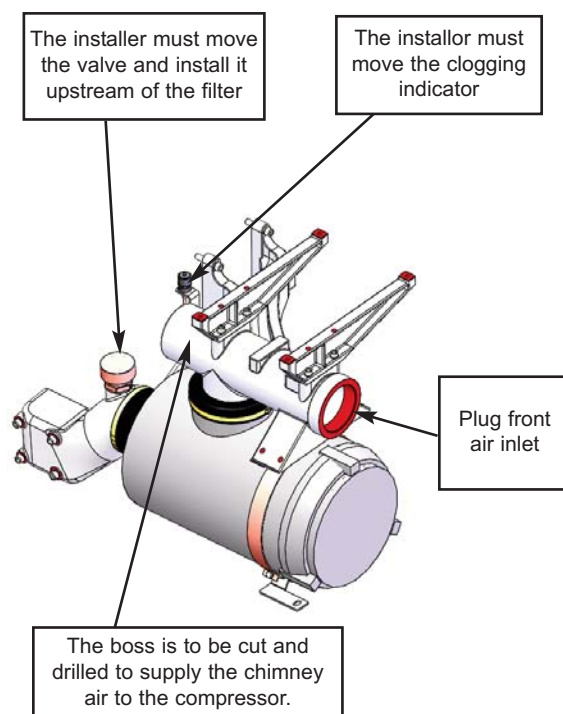

If this is the case, the air must be fed to the compressor from the rear of the filter box, on the boss, of diameter 130 cm for the purpose.

NB : The boss is not delivered pierced. The installer is responsible for piercing the aluminium on the inner passage assembly or cutting the edge of the boss. To prevent spillages during this operation from penetrating the compressor suction channel, it is important to leave the filters in place during the assembly operation. The filter box will be cleaned and the filters will be replaced before the compressor is put into service.

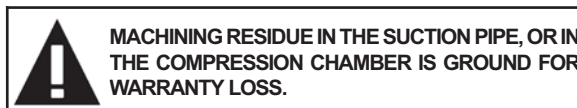

The installer is also responsible for mounting the filter clogging indicator somewhere visible to the truck driver under normal use of the compressor package.

2. INSTALLATION (continued)

2.3.3 Using the package

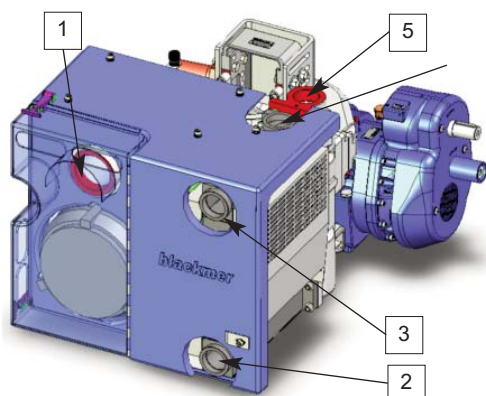

Suction mode:

The following precautions must be taken when using the XL DDIC package for suction :

- check that the system to be depressurised and the connecting pipes are able to withstand a vacuum.
 - the system must include safety valves in line with current regulations.
 - the system must be designed to prevent the inflow of liquid and dusts into the filter and the compressor.
 - the air or gas undergoing suction must be safe from the point of view of chemical aggressivity and the risk of explosion.
- open at least one discharge port (2), (3), (4), (5).
 - connect the suction hose to the inlet (1).
 - the clogging indicator may turn to red in this process mode.



Discharge mode :

- check the inlet (1) is not plugged, do not connect any hose.
- connect the discharge hose to the outlet (2), (3), (4) or (5).
- the clogging indicator must never turn to red in this process mode.





2.4 Check relief / Safety valve

XL DDIC packages include a safety valve and a check valve.

The check valve is for preventing the return of particles from the tanker to the compressor, especially when the compressor is switched off, when the tanker is still pressurised.

The valve was adjusted prior to delivery. This adjustment is sealed.

Any valve manipulation will void the guarantee. Only MOUVEX personnel or authorised service centers are qualified to adjust the safety valves.

	WARNING	
		THE USE OF A PACKAGE AT PRESSURES GREATER THAN THOSE RECOMMENDED MAY CAUSE DAMAGE TO EQUIPMENT OR SERIOUS INJURY.
Hazardous pressure can cause personal injury or property damage.		

The maximum valve setting is 2,5 bar, but it must take into account the rotating speed range specified in the compressor instructions.

2. INSTALLATION (continued)

2.5 Drive

2.5.1 Speed range

In order to comply with the machine directive, the rotating parts of the compressor package (shafts, torque limiter, universal joint, PTO ...) must not be accessible to the user or the driver under normal conditions. If necessary, it is the installer's responsibility to fit the necessary protection for preventing any damage to equipment or physical injury.

MOUVEX cannot be held responsible for consequences due to the absence of such protection on the final installation.

The compressor may be operated directly by a universal joint shaft, with or without a multiplier.

The selection of the drive mode will take into account :

- The compressor mounting configuration
- The driving shaft rotation direction
- The expected power requirement for the given application
- The acceptable rpm range for the driving equipment
- The acceptable rpm range for the compressor.



The use of compressors outside of their operating speed range can lead to property damage or serious injuries. See Compressor instructions for more details.

IMPORTANT :

Any system providing for a compressor being driven by a thermal motor must include a system making it possible to disengage the compressor at startup and stop of the motor.

In all cases, the drive must make it possible :

- To maintain the compressor rotation speed during load variations (pressure variations) .
- Not to subject the compressor to sudden or insufficient starts.

2.5.2 PTO shaft drive

It is mandatory to comply with the following instructions :

- The shaft must be dynamically balanced.
- Its length and its inclination must be as small as possible, see table
- The drive shaft slides perfectly well during rotation.
- The jaws of the universal joints are parallel.
- Coupling flanges show no eccentricity nor warping of the bearing surface.
- The angle formed by the universal joint and the drive shaft must not exceed 15°.
- The compressor shaft must be parallel to that of the drive shaft.
- The universal joint angle, as defined below, must be minimised.

XL DDIC packages incorporate a compressor gradient of 4° in relation to the horizontal. This gradient allows the recovery of the most recent PTO angles on current trucks. If your PTO angle is between 3 and 5° inclusive, you can install the chair vertically and respect operating recommendations.

If this is not the case, you should gently slope the chair to bring the angle between the compressor operating shaft and the PTO below 1°.

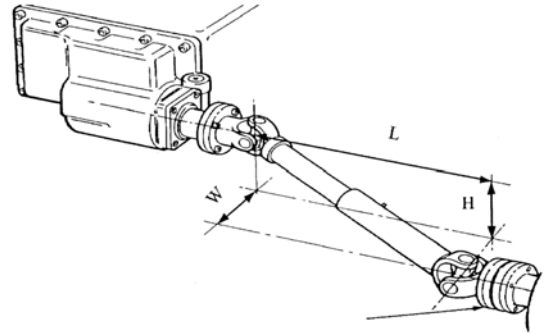

$$A = \frac{\sqrt{H^2 + W^2}}{L}$$

If H = Zero, A = W / L

If W = Zero, A = H / L

A	Universal joint angle	
0,017	1°	VERY GOOD
0,035	2°	
0,052	3°	
0,070	4°	
0,087	5°	
0,105	6°	GOOD
0,125	7°	
0,141	8°	
0,158	9°	
0,176	10°	LIMIT VALUES
0,194	11°	
0,213	12°	
0,231	13°	
0,249	14°	
0,268	15°	

It is possible to equip packages with a multiplier to lessen the universal joint angle. Refer to the compressor instructions for further information.

To protect the P.T.O in the event of compressor stalling, **it is necessary to install a torque limiter.** The MOUVEX company shall not be held responsible for damage resulting from such stalling if this stalling is caused by wrong manipulation with the compressor or if no or not the right torque limiter is installed.

2. INSTALLATION (continued)

The torque limiter will be installed on the compressor shaft, as illustrated in the photo below.

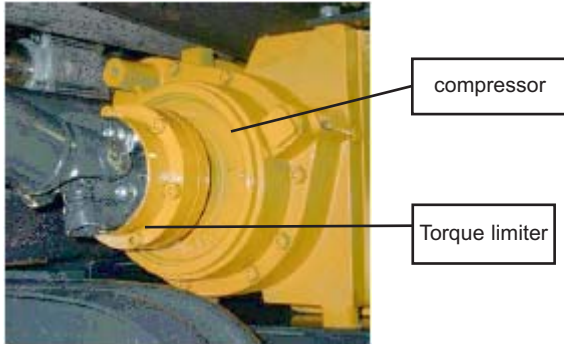

XL DDIC packages may be ordered with torque limiters mounted. Refer to Instructions 1401-B00 TORQUE LIMITER - SCREW COMPRESSORS.



If the greasing instructions for the universal joint are not respected, this can lead to ruptures of this universal joint, as well as property damage and serious injuries.

2.5.3 Installation of channelling

Channelling connected to the package must be designed in accordance with regulations to prevent premature breakdowns on the installation.

In particular, MOUVEX recommends taking the following precautions :

- Channelling must be supported so as to prevent them from mechanically loading the inlets and outlets on the compressor package.
- Suction and discharge channelling must have a diameter at least equal to that of suction and discharge connections on the compressor package.
- At the suction, you should limit sources of load loss (elbows, valves, lengths of channelling...).

2.6 Electric circuit

The XL DDIC package requires a power supply to run the cooler fan.

2.6.1 Electrical cabling suggested

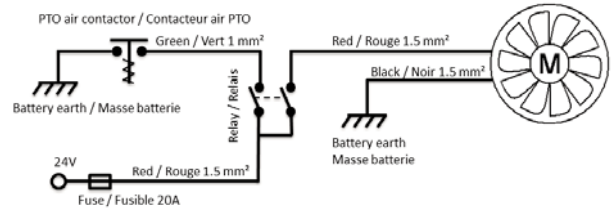

2.6.2 Connection procedure

Warning : The current source must be cut before any intervention in the electrical circuit to prevent any damage to equipment or physical injury.

The power supply for the package must be protected with a 20 A fuse (not supplied) on the power supply.

The electrical cable linking the compressor package to the power supply must be correctly supported to prevent its wear through friction, which could make the equipment live or cause unwanted microcuts.

The installer is responsible for supplying this electric line when the compressor is in use and switching it off when the compressor is not required.

To provide with power the fan use a relay able to switch 50 A. It could be controlled by a manual switch or automatic device that uses the command signal of the control drive (pneumatic or electric).

Turning off the fan while the compressor is running can cause damage to equipment or physical injury (failure of the fan or accessories on the cooled outlet ...).

When it is first used, you should check that the air is blown by the fan through the cooler. If the air is sucked in by the fan through the cooler, have another look at the cabling.

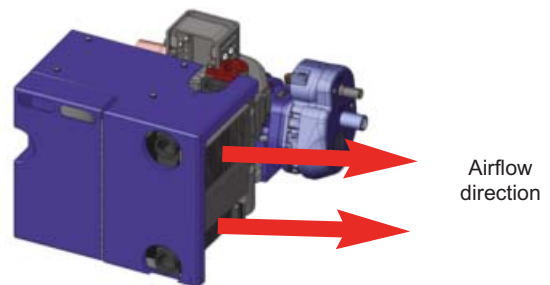

CAUTION :

Not respecting the direction of air circulation will lead to significant loss of cooler performance and fan reliability problems.

2. INSTALLATION (continued)

2.7 Instrumentation

The package is supplied with an suction filter clogging indicator.

Compressor functioning under pressure :

The maximum pressure drop at suction must be lower
A clogging indicator device turns red when the filter needs to be changed.

Vaccum operation :

The maximum vacuum authorised for the intake of the compressor is -8 bar, since the exhaust is into the atmosphere. Pressure less than 0,8 bar at the discharge of the compressor A vacuum breaker must be installed on the suction circuit in order not to exceed -0.8 bars at the compressor suction flange.

The clogging indicator is red during the vacuum operation. This is normal: after a vacuum operation, the clogging indicator must be released so it becomes transparent again.

REMINDER :

The clogging indicator must not be red when the compressor is in pressure operation.

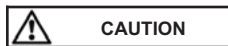

When the compressor is used in vacuum operation, the temperature of the air that escapes from the exhaust to the atmosphere may be more than 200°C. Make sure that the flow of hot air does not cause any damage to the surrounding elements. If necessary, provide for protections that prevent operators from touching the hot parts.

There should be visible labels close to the hot parts to warn about burns risk.

Once the filters have been replaced, the clogging indicator mat be reset to zero merely by rotating its cap.

2.8 Chair modification

No chair modification operation is permitted :

- Piercings
- Assembly operations
- Cutoff

risk of loss of MOUVEX warranty on the equipment.

3. MAINTENANCE

3.1 Maintenance schedules

See the Compressor instructions for the maintenance programme.

3.2 Air filter replacement procedure

Check weekly the clogging indicator. When it turns red, replace the filter cartridge.

Before installing a new cartridge, clean the internal part of the filter housing with a clean damp cloth.



The presence of foreign bodies in the compressor suction channel is susceptible of leading to serious property damage or serious injuries.

3.3 Cartridge replacement procedure

Unclasp the 3 clips to remove the cover filter.

Remove the cartridge with the filter reinforcement. Remove the filter reinforcement and place it in the new cartridge. Fit the cartridge with the filter reinforcement in the filter and close the cover filter by re-clasping the 3 clips.

3.4 Drive train inspection

Periodically check that there is no play in the jaws and PTO cross pieces, turning the universal joint manually in one direction then in the other direction.

3.5 Check valve and relief valve inspection

See Instructions 1401-E00 SCREW COMPRESSOR CHECK AND RELIEF VALVE.

3.6 Warranty claims

The following part are considered as wear part :

- Inlet filter cartridge
- Compressor oil

No failure connected with wear part damage will be accepted under warranty conditions.

The following situations will void warranty for all components of the package :

- Tampering with the setting of the relief valve.
- Presence of foreign body inside the compressor body.
- Traces of damage representative of abnormal use of the package.
- Use of non genuine parts.
- If the compressor is repaired by a repairer who is not a MOUVEX-approved repairer.
- Construction of the package not validated by our Design Office.
- Use of an oil other than BSC for a 13R/15L and 19R/22L compressor.

Before returning your equipment to the factory, you must first obtain an Equipment return approval (RMA) from our After Sales Department.

A Compressors form information shall be filled by the installer or distributor and send to MOUVEX in order to claim for a warranty.

4. TROUBLESHOOTING

CAUTION :
OBSERVE ALL SAFETY WARNINGS CONTAINED IN THIS MANUAL.

Problem	Possible origin	Possible solution
1. Pressure issue	Too much pressure drop.	To check pipes diameter.
	Relief valve damaged.	To check the opening point.
	No return valve damaged.	To check the proper operating of the No return valve.
2. Flow rate issue	Wrong Compressor speed.	To adjust the speed by taking care of the range allowed.
	Relief valve damaged.	To check the opening point.
3. Abnormal high temperature	Air filter clogged.	To clean the cartridge or to replace it.
	Air pressure too much high.	To see problems 1. / 2.
	Outside temperature too much high.	To respect the maximum external temperature allowed.
	Lack of oil.	To check the oil level.
	Compressor speed too much low.	To adjust the speed by taking care of the range allowed.
4. Inlet pressure drop > 75 mbar (Clogging indicator red)	Air filter clogged.	To clean the cartridge or to replace it.
	Air inlet hose folded.	To check the air inlet hose.
5. Compressor doesn't operate	Torque limiter damaged.	To replace the torque limiter.
	Transmission damaged.	To consult your Service point.
6. Torque limiter damaged	Screw Compressor damaged.	To consult your Service point.
	Wrong motor / transmission management.	To consult your Truck dealer.
	Oil too much viscous.	To be in compliance with the MOUVEX Instructions.
7. Oil leak	Too much oil.	To check the oil level.
	Oil breather clogged.	To clean the oil breather.
8. Vibrations	Wrong motor speed.	To increase the speed by taking care of the range allowed.
	Transmission damaged.	To check the driving shaft.
	Lack of rigidity of the chassis.	To be in compliance with the Truck Manufacturer Instructions.

5. STORAGE CONDITIONS

5.1 Compressor

The equipment must be systematically stored in an area sheltered from bad weather.

The equipment must bear its original protective components until it is installed in its final application.

If installation is interrupted, put back in place the original protective components or equivalent components.

5.2 BSC oil

In its unopened original container in a dry, frost-free and light-free place.

The maximum shelf life is approx. 60 months.

6. USE

The operator should remain nearby the equipment throughout the use to ensure the proper functioning of the system.

7. SCRAPPING

The compressor must be scrapped in compliance with the regulations in force.

During this operation, particular care must be paid to the drainage stages of the compressor.

8. COMPRESSORS FORM INFORMATION

Before any material return, it is required to get an authorization from MOUVEX.

	COMPRESSORS FORM INFORMATION	
MOUVEX After Sales Department Z.I. La Plaine des Isles 89000 AUXERRE - FRANCE	Tel : (33) 3 86 49 86 03 Fax : (33) 3 86 49 86 48	Date : Followed by : File :
In order to properly deal with the return material, please fill in this form.		
A – Name and address of user _____ _____ Person to contact : _____ Phone Nr : _____		
B – Name and address of installator _____ _____ Person to contact : _____ Phone Nr : _____		
C - Material's serial number _____	D - Starting up date _____	
Running time estimation _____ hours		
E - Installation details	F - Operating parameters	
<input type="checkbox"/> PTO flanged <input type="checkbox"/> Propshaft drive system (direct PTO drive) <input type="checkbox"/> 30R <input type="checkbox"/> 20R <input type="checkbox"/> 19R <input type="checkbox"/> 13R <input type="checkbox"/> 22L <input type="checkbox"/> 15L <input type="checkbox"/> 12R <input type="checkbox"/> 10L <input type="checkbox"/> Torque limiter <input type="checkbox"/> Pressure relief valve setting (value) <input style="width: 50px;" type="text"/> <input type="checkbox"/> Belt drive system <input type="checkbox"/> Package air cooler <input type="checkbox"/> Package RTI <input type="checkbox"/> Other (electric, thermic or hydraulic motor) _____ _____ _____ _____	<input type="checkbox"/> Compressor's speed <input style="width: 100px; height: 20px;" type="text"/> <input type="checkbox"/> Operating pressure <input style="width: 100px; height: 20px;" type="text"/> <input type="checkbox"/> Motor speed (tachometer) at the time of the incident <input style="width: 100px; height: 20px;" type="text"/> <input type="checkbox"/> PTO ratio <input style="width: 100px; height: 20px;" type="text"/> <input type="checkbox"/> Product transferred _____ _____ _____	
	G - Suction conditions	
	<input type="checkbox"/> Air connection on truck chimney <input type="checkbox"/> Direct air connection <input type="checkbox"/> Flexible pipe between filter and compressor <input type="checkbox"/> Inox pipe between filter and compressor	
H - DESCRIPTION OF THE FAILURE		
<input type="checkbox"/> Blocking <input type="checkbox"/> Leakage <input type="checkbox"/> Noise, vibration <input type="checkbox"/> Other _____ _____ _____ _____		
I - Has the machine been replaced by a new one ? If yes which is the serial number		<input style="width: 100px;" type="text"/>
J - Has the machine been replaced by a removed one ? If yes which is the serial number		<input style="width: 100px;" type="text"/>
K - Remarks and comments of the user about the problem :		
_____ _____ _____		
Please send us back this completed form by fax or E mail as quick as possible.		

rév.16/10/2013



DECLARATION UE DE CONFORMITE EU CERTIFICATE OF CONFORMITY – EU KONFORMITÄTSERKLÄRUNG



MOUVEX sas, ZI La Plaine des Isles – 2 Rue des Caillottes – 89000 Auxerre France, déclare que l'équipement suivant / declares the following equipment / erklärt, dass folgende Ausrüstung:

Modèle : _____ (A) Répondant aux spécifications indiquées dans l'ARC N° : _____ (B)
Designation / Bezeichnung Serial N° / Serien Nr According to the specifications recorded in the acknowledgment of order N°:
Entsprechend den Spezifikationen aus AB-Nr :

Pour la Sté MOUVEX sas, fait à Auxerre le : _____
For Mouvex sas company – Date : _____
Für die Fa Mouvex sas - Datum : _____

Responsible Quality Clients
Customer Quality Manager / Qualitätsbeauftragter

- Configuration :**
Konfiguration
(Pumpe / Kompressor, freies Wellenende)
- Type / Geräteart :**
- Pompe à mvt excentré (Eccentric Disc Pump / Ringkolbenpumpe)
 - Pompe péristaltique (Peristaltic Pump / Schlauchpumpe)
 - Pompe centrifuge (Centrifugal Pump / Kreiselpumpe)
 - Compresseur à Vis (Screws compressor / Schraubenverdichter)
 - Compresseur à palettes (Vaness compressor / Flügelzellenverdichter)
 - Refroidisseur Hydraulique (Hydraulic oil cooler / Hydraulikölkühler)
- Groupe de pompage / de compression
(Pumping Unit / Compressor Unit)
(Pumpen- / Kompressoraggregat)
- Pompe à lobes (Lobes Pump / Drehkolbenpumpe)
 - Pompe à palettes (Vaness Pump / Flügelzellenpumpe)
 - Autre pompe (Other Pump / Andere Pumpe)

Est conforme aux dispositions suivantes :

- Directive « MACHINES » 2006/42/CE et aux législations nationales (à transposer, portant sur les dispositifs de sécurité liés aux risques mécaniques et électriques applicables aux machines tournantes.
NF EN 809:2009 NF EN 1672-2:2009 NF EN ISO 13857:2008 NF EN 12162:2009
- Directive « ATEX » 2014/34/EU du 26 février 2014 et aux législations nationales la transposant; portant sur les appareils destinés à être utilisés en atmosphères explosibles. Conformité obtenue par application des normes :
NF EN 1127-1:1997 NF EN 13463-1:2009 NF EN 13463-5:2009 Certification ATEX délivrée par INERIS*, Organisme Certificateur, et portant le marquage suivant : (C)

Is in conformity with the provisions of the following Directive:

- « MACHINES » Directive 2006/42/EEC as transposed by the national legislation, concerning safety equipments and arrangements relative to mechanical and electric risks applicable to rotative machines.
NF EN 809:2009 NF EN 1672-2:2009 NF EN ISO 13857:2008 NF EN 12162:2009
- « ATEX » Directive 2014/34/EU (26 Feb. 2014) as transposed by the national legislation, concerning equipment intended to be used in explosive atmospheres. Conformity obtained by application of the standards :
NF EN 1127-1:1997 NF EN 13463-1:2009 NF EN 13463-5:2009 ATEX Certification delivered by INERIS*, Notified Body, and with the following marking: (C)

den Bestimmungen der nachstehenden Richtlinien entspricht:

- „Machines-Richtlinie“ 2006/42/EEC wie umgesetzt im nationalen Recht hinsichtlich der Ausrüstungssicherheit und Sicherheitsvorkehrungen bezogen auf mechanische und elektrische Risiken, die für rotierende Maschinen gelten.
NF EN 809:2009 NF EN 1672-2:2009 NF EN ISO 13857:2008 NF EN 12162:2009
- „ATEX“ Richtlinie 2014/34/EU (26. Feb. 2014) wie umgesetzt im nationalen Recht in Bezug auf Ausrüstungen für den Einsatz in explosionsgefährdeter Atmosphäre. Die Konformität hat Geltung durch Anwendung folgender Normen:
NF EN 1127-1:1997 NF EN 13463-1:2009 NF EN 13463-5:2009 Die ATEX-Zertifizierung wurde von der benannten Stelle INERIS* erteilt, und mit folgender Kennzeichnung: (C)



II G II T

Temp Max produit pompé / Max Temp Flow / Max. T° Medium = _____ °C (X = voir notice / see IOM / siehe Handbuch)

L'équipement désigné ci-dessus doit impérativement respecter les conditions d'utilisation ATEX décrites dans nos notices d'instruction. Il doit être employé conformément à l'utilisation qui en a été prévue de par sa conception et sa fabrication, et conformément aux normes en vigueur. Nous, soussignés, déclarons que l'équipement concerné est conforme aux Directives listées ci-dessus et aux normes applicables s'y rapportant.

The equipment indicated above must imperatively comply with the ATEX conditions of use described in our instruction book. It must be used according to the foreseen use by its design and its manufacturing, and according to the current standards. We, undersigned, declare that the concerned equipment is in conformity with the Directives listed above and in the applicable standards in force.

Oben stehend bezeichnete Ausrüstung muss unbedingt den in unseren Betriebsanleitungen beschriebenen ATEX Anwendungsbedingungen entsprechen. Sie ist entsprechend dem durch Konstruktion und Fabrikation vorgesehenen Verwendungszweck und entsprechend den geltenden Normen einzusetzen. Die Unterzeichner erklären, dass die bezeichnete Ausrüstung den oben aufgeführten Richtlinien und den diesbezüglich geltenden Normen entspricht.

CTRL-D025 – rév.04 du 25/05/2016 – Déclaration de conformité CE-Atex

* (INERIS – Parc Techno Alata – 60550 Verneuil-en-Halatte – France).