

Discharge Volume Checker FC-1 Flow Monitor FM-01 for Metering Pumps

OPERATION Manual

— *Before beginning operation, read this manual carefully!* —

- Thank you for purchasing this TACMINA product. Please read this manual carefully in order to ensure that you use the equipment safely and correctly.
- Be sure to keep this manual in a place where it will be easily available for reference.
- If you have purchased the product with special specifications different from this in this manual, please use it according to the terms of individual arrangements and drawings and the approval drawings and documents.

Introduction

Thank you very much for purchasing the TACMINA products.

These products are to be used with TACMINA metered pumps to monitor for discharge errors.

Before operating the product, please read this manual carefully so that you will have the use of the product for a long time.

■ When unpacking the product, please confirm the following items:

- (1) Is the enclosed product the same model that you ordered?
- (2) Are all the accessories present and correct? (Refer to Accessories on p.16.)
- (3) Is there any damage due to vibration or shock during transportation?
- (4) Are any screws or other fasteners loose or worked off?

We take all possible care with our shipments. However, in the unlikely event that you find any defect, please notify TACMINA or the distributor. We will do everything possible to take care of the matter.

Warranty

This product is guaranteed to be free of manufacturer defect for one year following delivery. In the event that a defect arises during the warranty period, TACMINA will strive to minimize losses by performing repairs or sending a substitute product or replacement parts without delay. However, please be aware the TACMINA cannot guarantee consumables, use of the product with pumps other than those indicated for application, improper use of the product, or malfunctions arising due to natural disaster or other forces beyond its control.

Contents

| | | |
|----|--|----|
| 1 | Outline | 1 |
| 2 | Principle of Measurement..... | 1 |
| 3 | Model Code..... | 1 |
| 4 | Specifications..... | 2 |
| | 4-1 Specifications..... | 2 |
| | 4-2 Liquid-End Material Table..... | 2 |
| 5 | Installation..... | 3 |
| | 5-1 Connection Directly to Pump..... | 3 |
| | 5-2 Connection by Hose..... | 6 |
| 6 | Wiring and Connecting with Peripheral Equipment..... | 7 |
| | 6-1 Power Supply Connection..... | 7 |
| | 6-2 Connecting to Flow Monitor | 7 |
| | 6-3 Connecting to Digital Panel Meter..... | 8 |
| 7 | Applicable Chemicals and Recommended Materials..... | 9 |
| 8 | Air Bleeding..... | 10 |
| 9 | Checking Operation | 11 |
| 10 | Maintenance | 12 |
| | 10-1 Joints | 12 |
| | 10-2 Main Unit | 13 |
| 11 | Accessories | 14 |
| | 11-1 Connection Directly to Pump..... | 15 |
| | 11-2 Connection by Hose..... | 15 |
| 12 | Flow monitor | 16 |
| | 12-1 Outline | 16 |
| | 12-2 Installation | 16 |
| | 12-3 Wiring | 16 |
| | 12-4 Names of Parts..... | 17 |
| | 12-5 Alarm Setting Method | 17 |
| | 12-6 Specifications..... | 18 |
| | 12-7 External Dimensions | 18 |
| 13 | Warranty | 19 |
| 14 | Repair Service..... | 20 |

1 Outline

This discharge volume checker has superior corrosion resistance and many other functions in its compact body. The flowmeter is best matched for use with the well-established N-feeder metering pumps (PX, NCS and S series).

2 Principle of Measurement

This is a positive displacement flowmeter that has an elliptical gear with a built-in magnet that turns with the flow of fluid. This rotation generates signals in the form of magnetic pulses.

3 Model Code

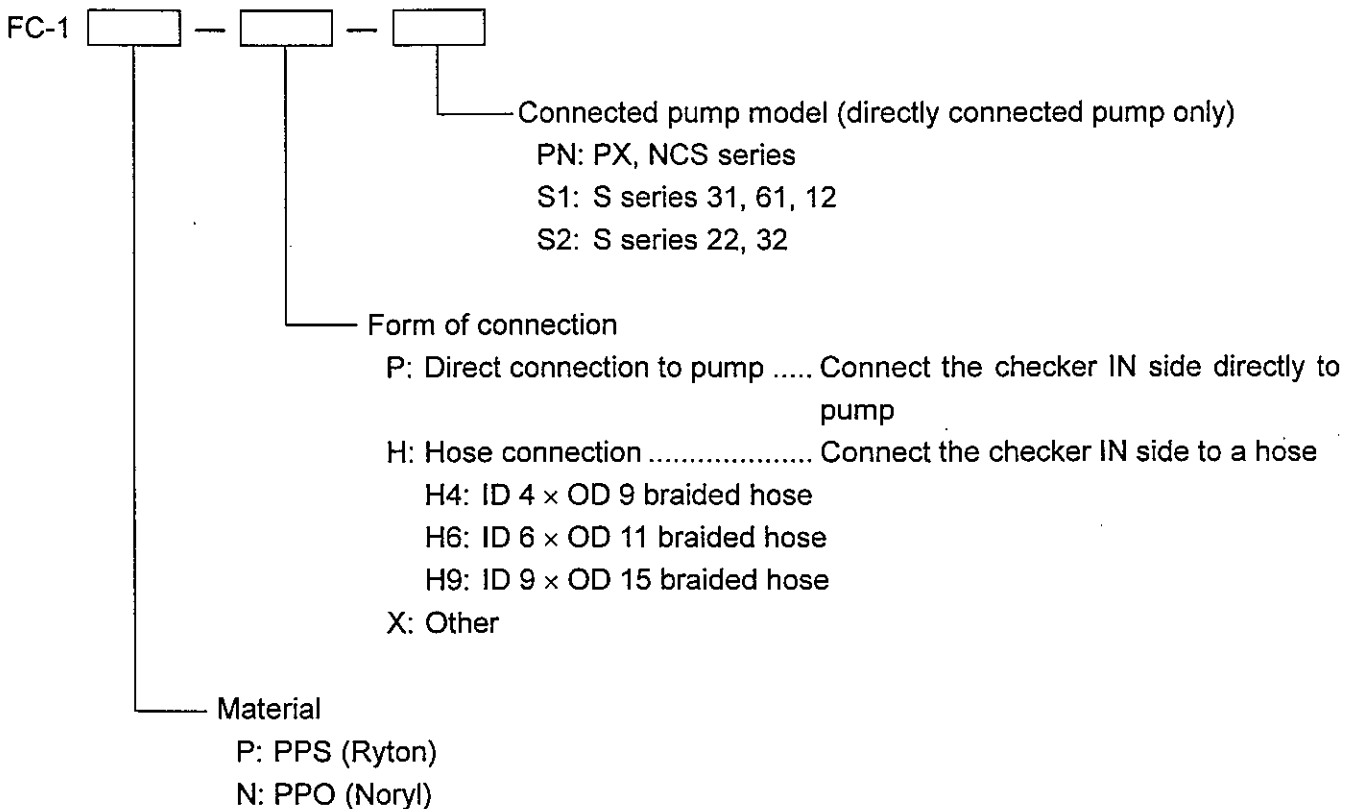

4 Specifications

4-1 Specifications

| Item | Specifications |
|---------------------------------|--|
| Applicable pumps | Models PX-31, 61, 12 Models NCS-11, 31, 61, 12, 22 Models SXD (W) (A) 1-61, 12, 32 Models SXD (W) (A)-31, 22 Models SYD (W) (A) 1-31, 61, 12, 32 |
| Pulse constant | 1 mL/pulse |
| Accuracy | ±10% |
| Normal operating pressure | 1.0 MPa or less |
| Peak maximum operating pressure | 1.4 MPa or less *1 |
| Liquid temperature | -10 to 50°C (no freezing) *1 |
| Ambient temperature | 0 to 40°C |
| Liquid viscosity | 1 to 50 mPa·s |
| Output | Open collector (collector capacity 30 V, 30 mA) When pulse output is high, the green LED lights up. |
| Power supply | 4.5 to 25 VDC (20 mA max.) When power is ON, the red LED lights up. |
| Connection port aperture | ID 4 × OD 9 or ID 6 × OD 11 or ID 5 × OD 9 or ID 9 × OD 15 braided hose |
| Air bleed aperture | ID 4 × OD 6 hose |

*1 However, do not exceed the maximum operating pressure or temperature range of the applicable pump.

Cautions on Operation

- Check the pressure, temperature, and so on for the application metering pump specified on the nameplate and use the pump within the correct ranges.
- Be sure to operate the pump within the operating temperature range.

4-2 Liquid-End Material Table

| Name | FC-1P-H | FC-1N-H |
|-----------------|---------|-----------------------|
| Sensor | PPS *1 | PPO *2 |
| Check ball | Ceramic | Ceramic |
| O-ring | EPDM | Fluoro-rubber |
| Valve seat | EPDM | Special fluoro-rubber |
| Ball stopper | FRPP | PVC |
| Air-bleed valve | PE | PE |

*1 PPS: Polyphenylene sulfide resin (Ryton)

*2 PPO: Polyphenylene oxide resin (Noryl)

5 Installation

5-1 Connection Directly to Pump

- When attaching to an existing PX series pump

The installation procedure is shown in the illustration below.

*1 The section shown enclosed in a frame in the illustration uses the same parts as the PX series metering pumps.

*2 The section shown enclosed in a frame in the illustration is not used here, so be sure to keep it in safe storage.

- (1) When detached, check the O-rings and check balls for damage, and check the valve seat for the presence of debris or other matter.

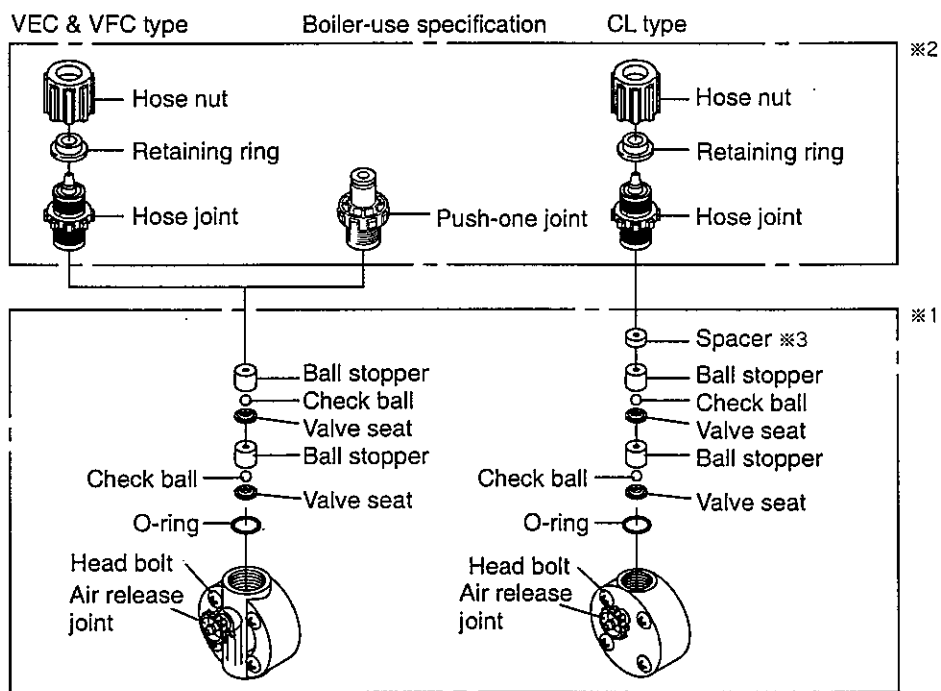

PX • NCS pump

- When attaching to an existing NCS series pump

The installation procedure is shown in the illustration below.

*1 The section shown enclosed in a frame in the illustration uses the same parts as the NCS series metered pumps.

*2 The section shown enclosed in a frame in the illustration is not used here, so be sure to keep it in safe storage.

- (1) When detached, check the O-rings and check balls for damage, and check the valve seat for the presence of debris or other matter.
- (2) When assembling, be sure that the valve seats and ball stoppers are oriented correctly and that each direction of joints is otherwise assembled properly.

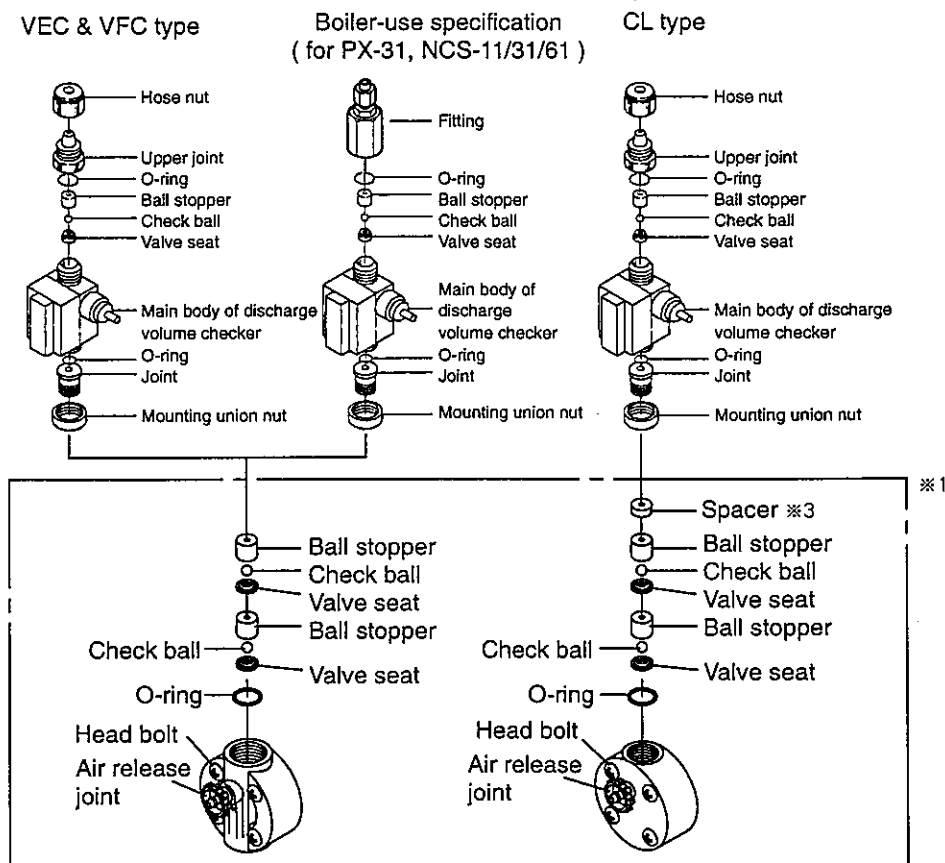

With discharge volume checker

- When attaching to an existing S series pump

The installation procedure is shown in the illustration below.

*1 The section shown enclosed in a frame in the illustration uses the same parts as the S series metered pumps.

*2 The section shown enclosed in a frame in the illustration is not used here, so be sure to keep it in safe storage.

(1) When detached, check the O-rings and check balls for damage, and check the valve seat for the presence of debris or other matter.

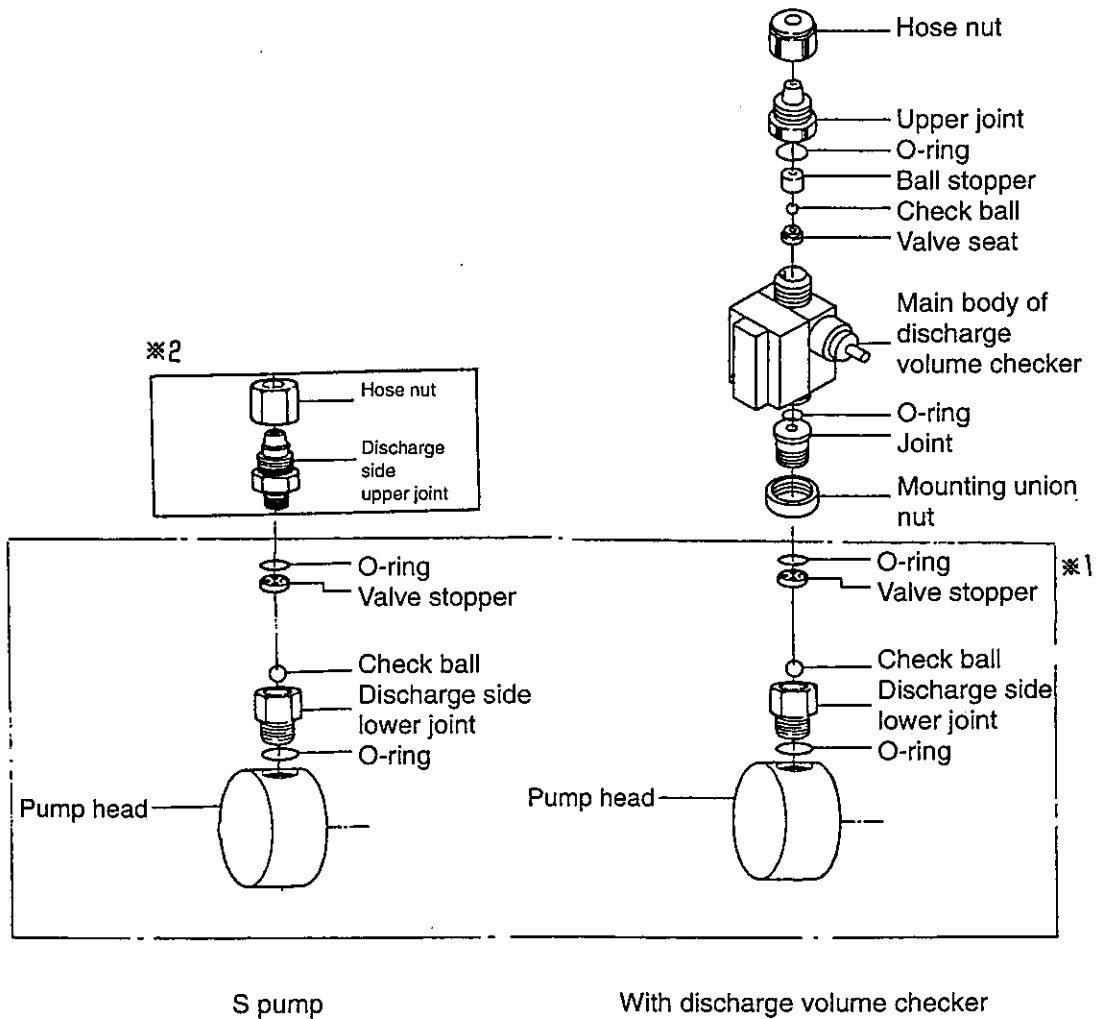

Piping

- ① Align the discharge volume checker so that the arrow symbol on the front panel nameplate points the direction of fluid flow.
 - ② When installing pipe, take care to prevent debris or foreign matters from entering the pipe.
- This product is not applicable for fluid that contains slurry.

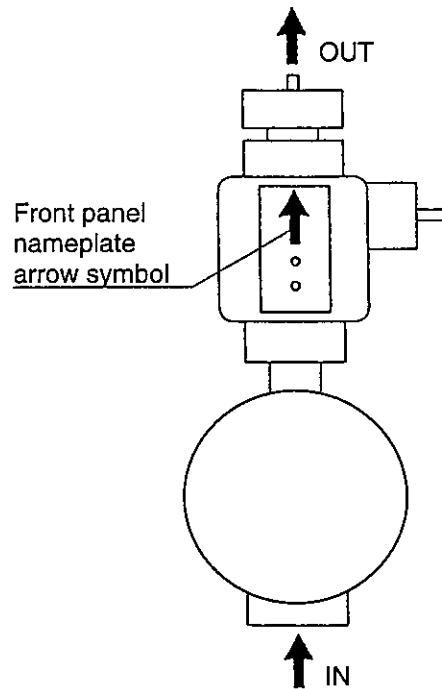

5-2 Connection by Hose

- (1) Attach this product to the delivery side (discharge side) of the pump. It may not operate properly if attached to the suction side (intake side).
 - (2) Align the discharge volume checker so that the arrow symbol on the front panel nameplate points the direction of fluid flow.
 - (3) Install the flowmeter so that the front panel is vertically positioned.
 - (4) Install the flowmeter as close to the pump head as possible.
 - (5) When installing pipe, take care to prevent debris or other foreign matter from entering the pipe.
- * This product is not applicable for fluid that contains slurry.

6 Wiring and Connecting with Peripheral Equipment

6-1 Power Supply Connection

- The power supply should be 4.5–24 VDC, maximum 20 mA.

Connect the red wire to the positive terminal and the black wire to the negative terminal.

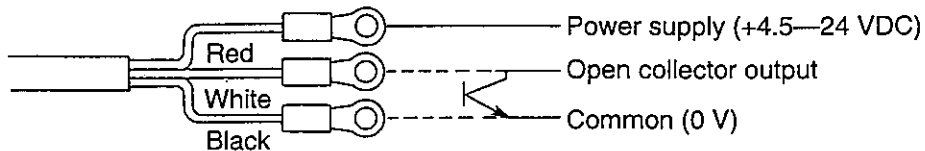

6-2 Connecting to Flow Monitor

Flow monitor

Discharge volume checker

Terminal

Lead wire

| | | | |
|---|---------|-------------------------|------------------------------------|
| ① | CELL | — Common | Black |
| ② | | — Signal | White |
| ③ | | — Power supply (12 VDC) | Red |
| ④ | GND | | |
| ⑤ | 0 VAC | Power supply | |
| ⑥ | 100 VAC | | |
| ⑦ | 200 VAC | | |
| ⑧ | C | ALARM | Alarm contact |
| ⑨ | A | | |
| ⑩ | B | | |
| ⑪ | — | IN | Interlock (Non-voltage contact) |
| ⑫ | — | | |
| ⑬ | GND | | |

- The transmission distance is 50 m or less.

6-3 Connecting to Digital Panel Meter

Lead wires Terminals
 (Red) DC+ → 8
 (Black) → 7
 (White) Signal → 9

Numbers 9 and 10 are open. (Remove the short-circuit pin)

- The transmission distance is 50 m or less.

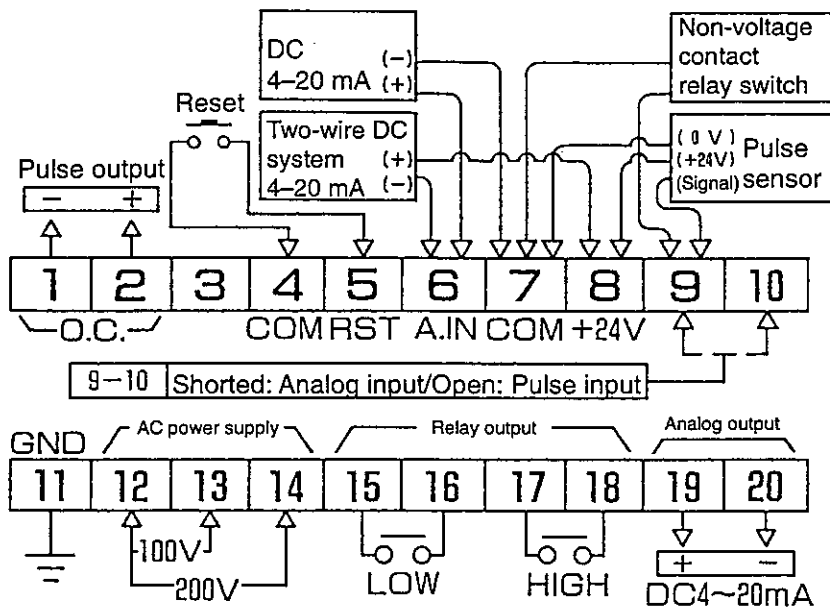

7 Applicable Chemicals and Recommended Materials

| Chemical | Discharge volume checker material | Applicable pump | PX | | NCS | | S-31, 61, 12 | | S-22, 32 | |
|-------------------------------|-----------------------------------|-----------------|--------|--------|------------------------|--------|------------------------------------|--------|----------|--------|
| | | | When H | When P | When H | When P | When H | When P | When H | When P |
| Sodium hypochlorite 12% | N | | -H4 | -P-PN | -H4 | -P-PN | -H4 | -P-S1 | -H6 | -P-S2 |
| Pump liquid-end part material | | | CL | CL | CL | VTC | | | | |
| Boiler compound *1 | P | | -H4 | -P-PN | -H4 | -P-PN | -H4 | -P-S1 | -H6 | -P-S2 |
| Pump liquid-end part material | | | VEC | VEC | VEC | VEC | | | | |
| Sulfuric acid 1N | P | | -H4 | -P-PN | -H4 | -P-PN | -H4 | -P-S1 | -H6 | -P-S2 |
| Pump liquid-end part material | | | VEC | VEC | VEC | VEC | | | | |
| Sodium hydroxide 10% | P | | -H4 | -P-PN | -H4 | -P-PN | -H4 | -P-S1 | -H6 | -P-S2 |
| Pump liquid-end part material | | | VEC | VEC | VEC | VEC | | | | |
| Sodium hydroxide 20% | P | | -H4 | -P-PN | -H4 | -P-PN | -H4 | -P-S1 | -H6 | -P-S2 |
| Pump liquid-end part material | | | VEC | VEC | VEC | VEC | | | | |
| Sodium hydroxide 30% | P | | -H4 | -P-PN | -H4 | -P-PN | -H4 | -P-S1 | -H6 | -P-S2 |
| Pump liquid-end part material | | | VEC | VEC | VEC | VEC | | | | |
| Aqueous ammonia | P | | -H4 | -P-PN | -H4 | -P-PN | -H4 | -P-S1 | -H6 | -P-S2 |
| Pump liquid-end part material | | | VEC | VEC | VEC | VEC | | | | |
| Methyl alcohol | P | | -H4 | -P-PN | -H4 | -P-PN | -H4 | -P-S1 | -H6 | -P-S2 |
| Pump liquid-end part material | | | VEC | VEC | VEC | VEC | | | | |
| Notes | | | | | NCS-52 cannot be used. | | Cannot be used with S-62 or above. | | | |

Note 1 *1 When using boiler compounds based on sodium hypochlorite, select Noryl materials.

Note 2 Concentrated hydrochloric acid (35%), hydrochloric acid (1N), and concentrated sulfuric acid (98%) cannot be used.

8 Air Bleeding

When first using the product, and when changing the liquid being transferred, air bleeding should be performed before operation. (See illustration on next page.)

- ① Set the pump stroke length adjustment dial to 100%.
- ② Attach the accessory hose (ID 4 × OD 6) to the air bleed nozzle, and return the other end to the transfer liquid tank.
- ③ Turn the air bleed plug on the discharge volume checker counterclockwise (toward OPEN) to open it slightly, then turn on the pump power.
Be careful not to open the plug too far. For safety, always be sure to wear rubber gloves, face mask, protective goggles, and other protective coverings appropriate for the chemicals when performing an air bleeding operation.
- ④ With the pump running, completely fill the suction pipe and pump head section with transfer liquid. Liquid spurts from the air bleed nozzle when the pump head section and the inside of the checker are filled with the liquid, so be very careful not to allow any fluid to come in contact with your body.
- ⑤ After air has been completely purged, tighten the air bleed plug.
- ⑥ If the pump stroke length adjustment dial setting was changed, return it to its previous setting.

9 Checking Operation

- ① When the power is connected, the power supply LED (red) and the operating signal LED (green) will go on.
(The operating signal LED may not be lit, depending upon the position of the magnet.)
- ② The flow of 1 mL of liquid will cause a single pulse signal, and simultaneously the operating signal LED (green) will blink once.

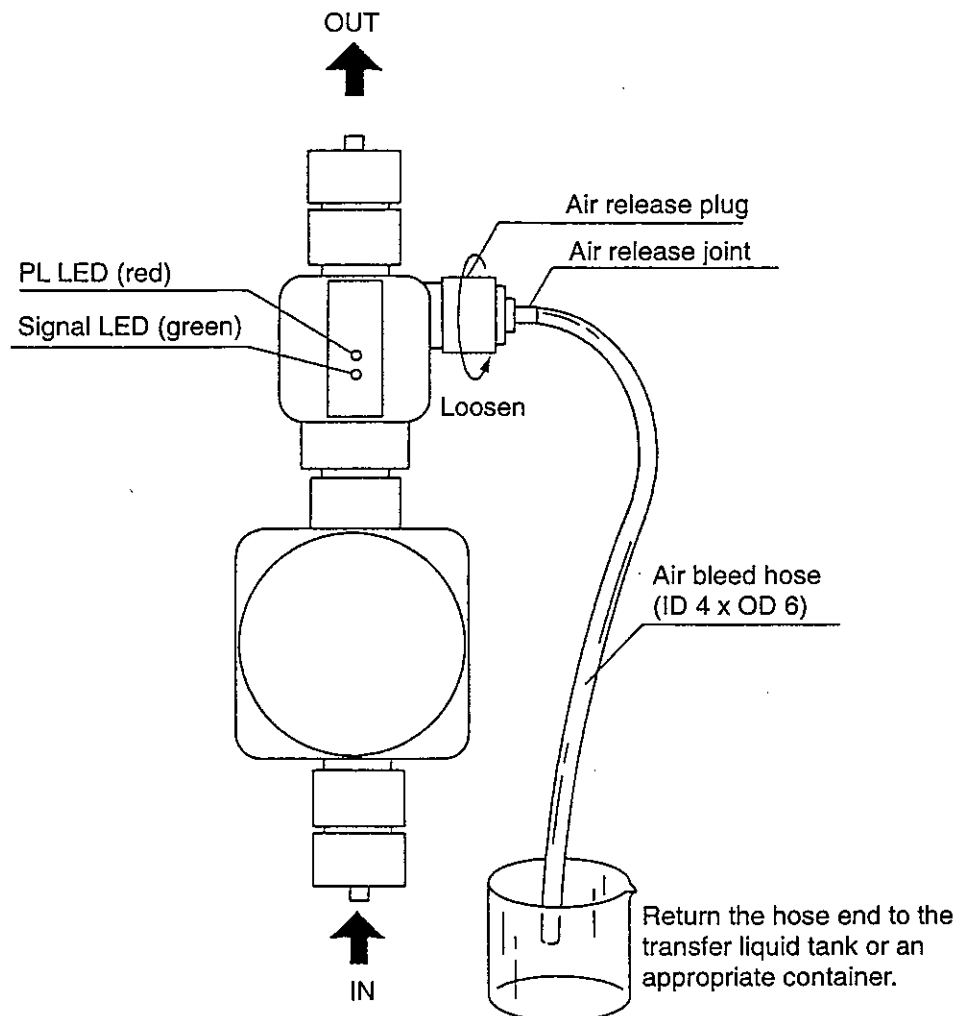

10 Maintenance

There should be no particular need for maintenance if the product is used with the correct range for flow rate and other conditions. If malfunctions occur in the pulse output or if no pulse is generated, however, follow the below procedure for disassembly, inspection, and cleaning:

10-1 Joints

Refer to the illustration below when disassembling and assembling the unit. Remove joint parts and check for the presence of debris or foreign matters in the ball guide and valve seat.

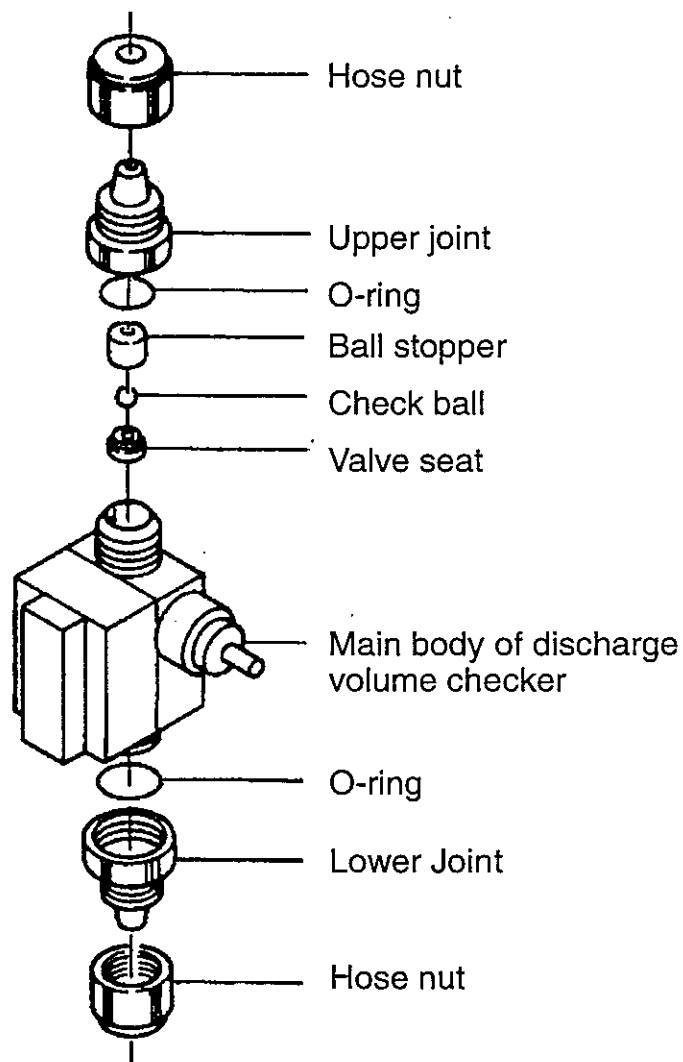

10-2 Main Unit

- ① Remove the nameplate.
(It is attached to the sensor case by double-sided adhesive tape.)
- ② Use a screwdriver to remove the two screws inside the sensor case, and remove the sensor case from the main unit.
- ③ Use a screwdriver to remove the four bolts, detach the plate, and remove the rotor.
- ④ Use a compressed air gun or similar tool to blow off debris inside the unit and on the rotor. When doing this, be careful not to let the pressurized air blow off any parts.
(Do this using air pressure of 0.1–0.2 MPa.)
- ⑤ The rotor without holes contains a magnet inside. Check that no iron powder or other debris is adhering to the rotor.
(If there is such debris, clean the rotor again with pressurized air.)
- ⑥ Replace the rotor in the case.
The rotor has defined top, bottom, and sides, so make sure it is oriented correctly.
(See illustration on next page.)
Also be sure not to forget to replace the O-ring.
- ⑦ Turn the rotor one or more times by hand to make sure it is properly engaged. Also check at this time to make sure the rotor turns smoothly and easily.
- ⑧ Fit the plate back on and insert all four bolts loosely, then finish tightening them in diagonally opposed corners, in that order. The bolts should be tightened to a torque of approximately 25 kgf/cm. If the bolts are not tightened sufficiently, the product will not operate with its rated accuracy.
- ⑨ Fit the sensor case back on and tighten the two screws, then replace the nameplate.

Rotor containing a magnet
(The one with holes plugged)

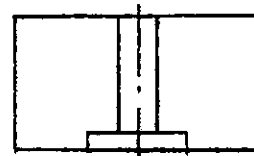
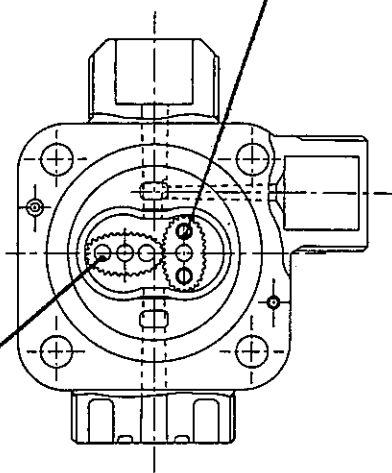

Insert the side with
the larger spot-facing first.

Rotor not containing a magnet
(The one with holes open)

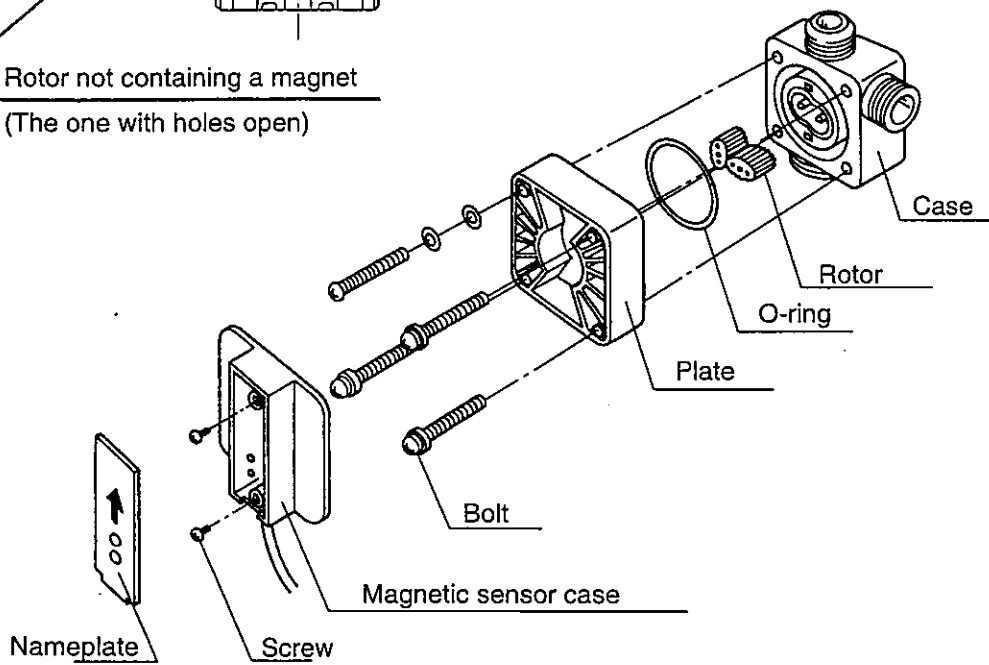

11 Accessories

11-1 Connection Directly to Pump

- | | | | |
|---|------------------|-------------|------------------|
| ① | Air bleed hose | ID 4 × OD 6 | 1 piece 1-m hose |
| ② | Operation manual | | 1 volume |

11-2 Connection by Hose

- | | | | |
|---|------------------|-------------------|--------------------|
| ① | PVC braided hose | ID 4 × OD 9 (H4) | 1 piece 50-cm hose |
| | | ID 6 × OD 11 (H6) | |
| | | ID 9 × OD 15 (H9) | |
| ② | Air bleed hose | ID 4 × OD 6 | 1 piece 1-m hose |
| ③ | Operation manual | | 1 volume |

12 Flow monitor

12-1 Outline

This flow monitor is discharge volume alarm device for metering pumps to use in combination with a discharge volume checker.

It monitors the metering pump discharge failure by outputting an alarm when a metering pump does not send a discharge signal within a specified time interval.

When fine settings are required, please make use of the Digital Panel Meter NDP-100 Series, which is sold separately.

12-2 Installation

The unit is DIN rail mounted. (Refer to external dimensions diagram on next page.)

12-3 Wiring

A wiring diagram is shown at the right. Refer to this and follow the cautions in order to wire the product correctly.

- (1) Connect the power supply ground to the GND terminal.
At this time, the ground should be earthed separately from the power system.
- (2) Connect the input signal line shield to terminal 1.
- (3) The input signal line should use piping separate from the power line. The maximum extension length between the flow monitor and the discharge volume checker is 50 m.

The extension cable should be a three-conductor with shield (diameter 0.75 mm or larger).

- (4) The interlock (non-voltage contact) must be connected in order for the alarm to operate.

Discharge volume checker wires

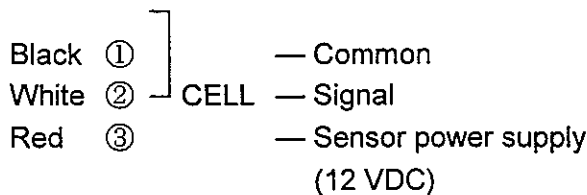

Wiring Diagram

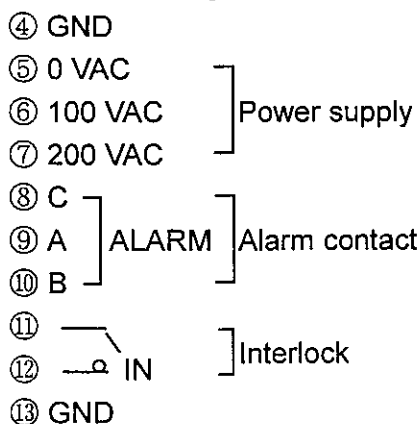

12-4 Names of Parts

- ① Power supply and input LED (PL)
This LED lights up when the power is on, and flashes when an input signal is received.
- ② Alarm LED (ALARM)
This LED lights up when an alarm is output.
- ③ Time setting knob (TIME)
This knob is used to set the alarm time. The time can be set within a range of 5–55 seconds.
- ④ Terminal block 1
The discharge volume checker is connected to this terminal block.
- ⑤ Terminal block 2
The power supply, alarm contact, and interlock (pump interlock signal) are connected to this terminal block.

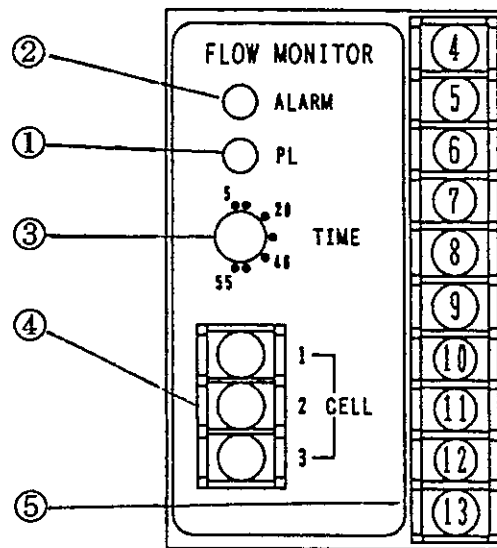

12-5 Alarm Setting Method

Follow the below example to set the time of alarm operation, allowing ample margin of delay.

[Example of setting]

When setting the alarm to output when discharge volume goes below 6 mL/min

Time setting: 60 seconds / 6 (discharge volume/mL) × 1.5 (delay ratio) = 15 seconds

[Explanation]

The discharge volume checker output is 1 mL/P, so when the discharge volume is 6 mL/minute, it will output 6 pulses. Therefore, the theoretical time setting would be 10 seconds.

For the actual setting, this value is multiplied by a delay ratio of about 1.5.

[Setting range]

| Time setting | Alarm setting discharge volume |
|---|---|
| 5 seconds minimum to 55 seconds maximum | Approximately 18 mL to Approximately 2 mL |

[Caution]

- Use a small screwdriver to set the time adjustment knob (TIME) to about 15.
- Turn it clockwise for a longer time setting.
- * The knob control is not specially reinforced, so do not use force to turn it.

12-6 Specifications

| | |
|---------------------|--|
| Model | FM-01 |
| Time setting | 5–55 seconds |
| Input | Sensor input : Open collector (Discharge volume checker signal: 1 mL/P) Interlock : Non-voltage contact |
| Sensor power supply | 12 VDC 30 mA |
| Alarm | Output contact 1C |
| Contact capacity | 200 VAC 1 A (Resistance load) |
| Display | Power supply and input pulse : Green LED on Alarm : Red LED on |
| Power supply | 100 VAC or 200 VAC $\pm 10\%$ (select terminals) |
| Power consumption | Approximately 5 VA |
| Mounting | DIN rail-mounted (for box enclosure) |

12-7 External Dimensions

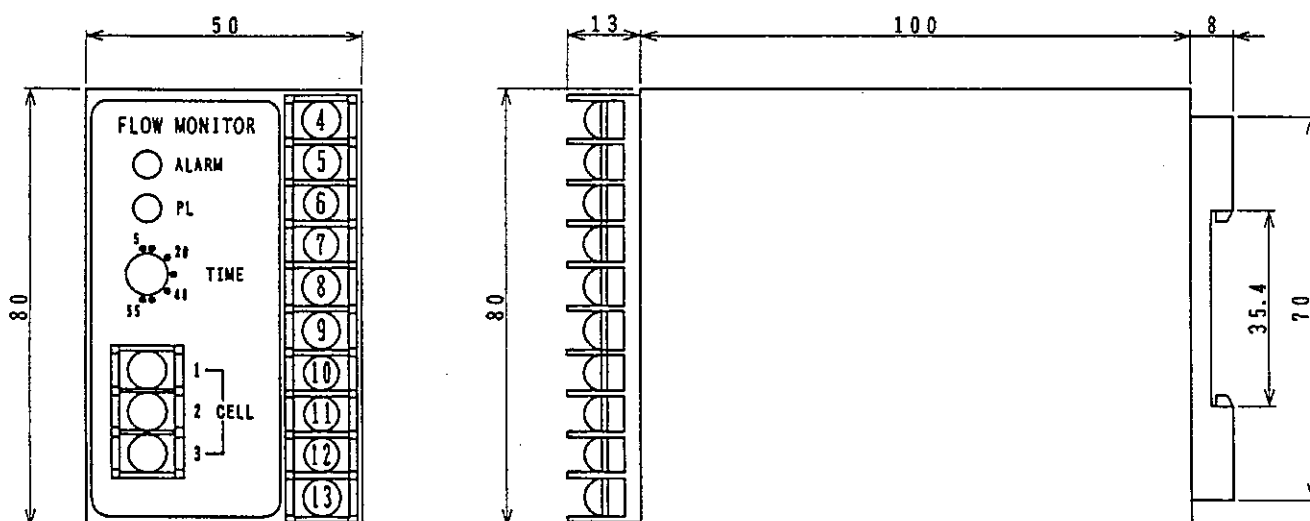

13 Warranty

■ Period and Range of Warranty

- (1) The warranty is effective for a period of one full year from the date of delivery.
- (2) If, during the warranty period, the product sustains damage or breakdown despite normal use and proper maintenance as a result of design or manufacturing defect, TACMINA will arrange for repair of the product at no charge to the customer.
However, the customer will be charged for the following expenses:
 - ① Replacement of consumables (parts that require regular replacement).
- (3) The customer will be charged for repair of the product or replacement in the event of damage or breakdown in the following cases.
 - ① Damage or breakdown occurring or reported after the guarantee period has expired.
 - ② Damage or breakdown resulting from careless handling or abnormal operating or maintenance procedures.
 - ③ Damage or breakdown resulting from the use of parts not made or specified by TACMINA.
 - ④ Damage or breakdown resulting from repair or remodelling not specified by or using parts not made by TACMINA.
 - ⑤ Damage or breakdown resulting from fire, act of God, natural disaster or other unforeseeable circumstances.
 - ⑥ Damage or breakdown resulting from the use of materials or parts specified or supplied by the customer.
- (4) In case there is doubt about the cause of the damage or breakdown, the customer and TACMINA will consult on the matter and abide by the result of the consultation.
- (5) Chemical-proof and liquid handling performance of the product with regard to the liquids used by the customer are not covered by this warranty. The liquid-end part materials selected at the time of order are recommended materials and their chemical-proof performance and so on are not covered by warranty.
- (6) TACMINA cannot accept responsibility for any other damage, accident or loss resulting from the breakdown or malfunction of this product.

14 Repair Service

If any abnormality is detected during operation, immediately stop operating the pump and inspect to determine whether it is a malfunction or not.

Before requesting repair, read the operation manual carefully and double-check the possible cause of problems. In the event that the failure needs outside repair work, please contact the store where you purchased the product.

(1) Within the warranty term

Present the warranty document to the store where you purchased the product. The store will arrange the repair according to the warranty contents.

(2) After expiration of the warranty term

Consult the store where you purchased the product. Depending on the type of repair required and whether the pump's functions can be maintained, the store will perform repair according to the customer's request for a charge.

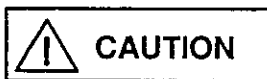

To return the article for repair, be sure to observe the following points in order to maintain the operator's safety and preserve the environment:

- Wash out the liquid-end part and outside of the pump thoroughly and return it together with the maintenance service datasheet and the safety data sheets (MSDS) for liquids used.
- If the maintenance service data sheet or safety data sheet (MSDS) does not accompany the product, repair work cannot be carried out.
- Even if the maintenance service data sheet or safety data sheet (MSDS) are provided, TACMINA reserves the right to refuse to repair the product if we determine it to be too dangerous.

■ Minimum Keeping Period for Performance Spare Parts for Repair

It is TACMINA's policy to keep on hand a stock of spare parts that are vital to the performance and functionality of our products for a minimum of five years after we stop producing a particular model

EM-036 0011 05 IOO

Liquid Control Technology

TACMINA CORPORATION

Head Office: Daihyaku-Seimei Bldg., 2-4-8,
Minami-Semba, Chuo-ku, Osaka 542-0081, Japan.
Tel. +81-6-6271-3971 Fax. +81-6-6271-4677
URL <http://www.tacmina.co.jp>
E-mail joint@tacmina.co.jp